

Compilation of Constructed Response Items

Measures of Student Learning: NC's Common Exams

Released Fall 2012

These released test items may be used by school systems to help acquaint students with constructed response items on the Measures of Student Learning: NC's Common Exams. These materials must not be used for personal or financial gain.

Table of Contents

	Page
Mathematics	1
Advanced Functions and Modeling	1
Rubrics---Advanced Functions and Modeling	4
Appendix to Constructed Response Key Advanced Functions and Modeling	9
Algebra II/Integrated III	10
Rubrics---Algebra II/Integrated III	13
Appendix to Constructed Response Key Algebra II/Integrated III	16
Geometry	17
Rubrics---Geometry	21
Appendix to Constructed Response Key Geometry	26
Pre-calculus	27
Rubrics---Pre-calculus	30
Appendix to Constructed Response Key Pre-calculus	34
English Language Arts	35
English Language Arts I	35
Rubrics---English Language Arts I	37
English Language Arts III	38
Rubrics---English Language Arts III	40
English Language Arts IV.....	41
Rubrics---English Language Arts IV.....	43
Social Studies	45
American History I.....	45
Rubrics---American History I.....	49
American History II	54
Rubrics---American History II	57
Civics and Economics	60
Rubrics---Civics and Economics	63
World History	66
Rubrics---World History.....	69
Science	73
Chemistry	73
Rubrics---Chemistry	75
Appendix to Constructed Response Key Chemistry.....	77

Earth/Environmental Science	78
Rubrics---Earth Environmental Science	80
Appendix to Constructed Response Key Earth Environmental Science....	82
Physical Science	83
Rubrics---Physical Science	85
Appendix to Constructed Response Key Physical Science	87
Physics	88
Rubrics---Physics	91
Appendix to Constructed Response Key Physics	94



The questions you read next will require you to answer in writing.

1. Write your answers on separate paper.
2. Be sure to write your name on each page.

- 1 The chart below shows the amount of insulin in a person's bloodstream after a certain amount of time, t .

t (minutes)	3	15	24	45
Units of Insulin	8.6	4.9	3.1	1.0

Create a best fit exponential function to answer the questions.

- To the nearest tenth, how many units of insulin are in the person's bloodstream at $t = 0$?
 - To the nearest percent, what is the absolute value of the percent change per minute of insulin?
- 2 A geologist is analyzing the erosion of a coastline over the past five years. The table below shows the relationship.

Time (years)	1	2	3	4	5
Cumulative Erosion (feet)	1.01	2.81	6.51	10.14	16.32

- Does a linear, exponential, or power function best fit the data? Explain.
- Write the equation of the function that best models the data.
- Using the equation created, how much erosion can be expected after 8 years?



- 3 A restaurant determined that the calories of its meals are normally distributed. The mean is 680 calories with a standard deviation of 63 calories.
- Give a range of calories, centered on the mean, that includes 95% of the restaurant's meals.
 - The cook creates a meal with 617 calories. What percentage of meals has more calories than this meal?

- 4 The table below shows the cumulative frequency of student achievement scores for a particular class.

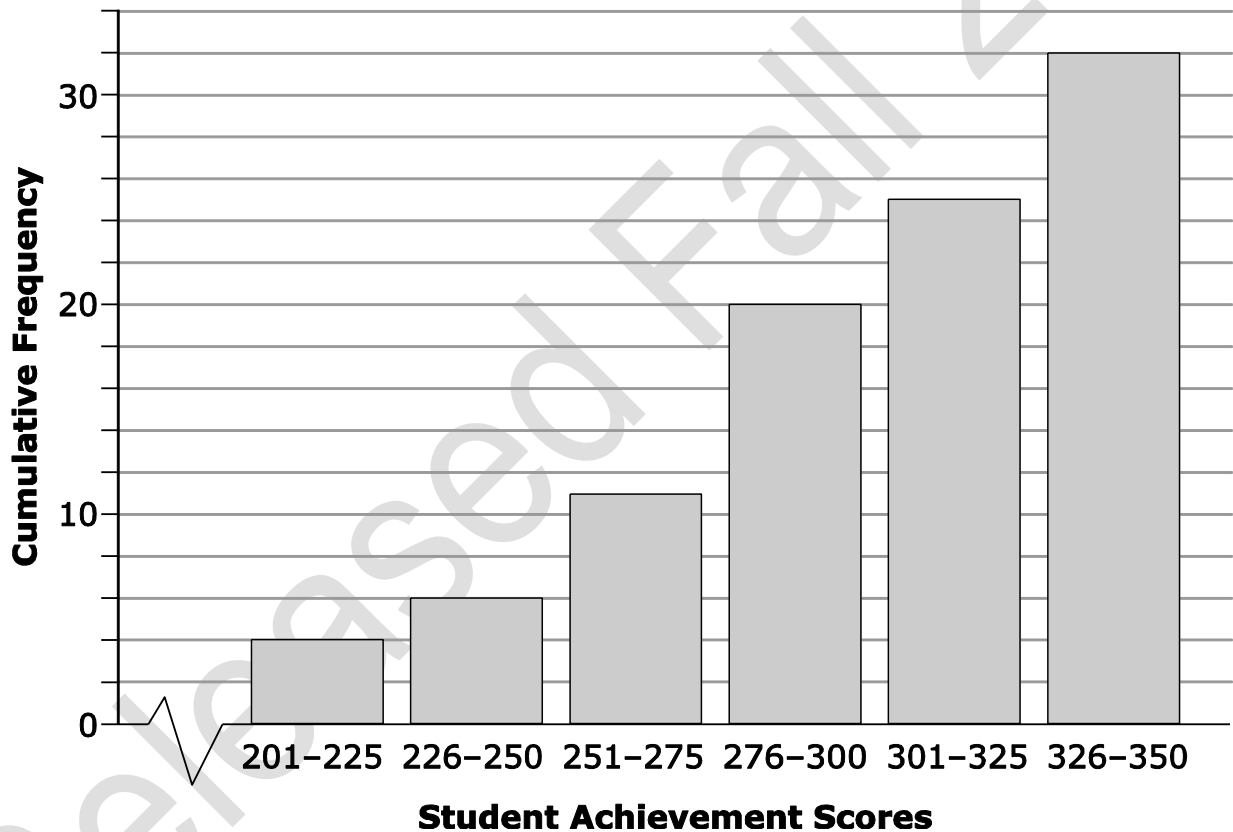

- Which 25-point interval contains the median achievement score?
- How many students scored at least a 276 on the achievement test?

ADVANCED FUNCTIONS AND MODELING

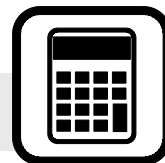

5 A professor of a statistics class has the following scores for her students: 296, 332, 290, 308, 343, 371, 336, 384, 361, 350.

- If 10 points are added to each score, what is the new mean and standard deviation?

6 Use the piecewise function below to answer each question.

$$h(x) = \begin{cases} -2x^2 + 5x + 10 & \text{for } -4 \leq x < 3 & \text{Step 1} \\ 3x + 2 & \text{for } 3 \leq x < 7 & \text{Step 2} \\ \sqrt{2x - 5} & \text{for } 7 \leq x < 16 & \text{Step 3} \end{cases}$$

- What is the range for step 1?
- What is the domain for the entire function?
- What is $h(10.5)$?

7 For the following problem, round each answer to the nearest hundredth.

- Write the equation of the power function that passes through the points (1, 6) and (3, 14).
- Based on the above function, what is the value of x when $y = 8$?

8 Power functions can be written in the form $f(x) = ax^b$, where $b > 1$.

- Write an equation for an odd, positive-integer power function of this form.
- Graph the equation including enough of the domain to show the graph's important features.



1. The chart below shows the amount of insulin in a person's bloodstream after a certain amount of time, t .

t (minutes)	3	15	24	45
Units of Insulin	8.6	4.9	3.1	1.0

Create a best fit exponential function to answer the questions.

- To the nearest tenth, how many units of insulin are in the person's bloodstream at $t = 0$?
- To the nearest percent, what is the absolute value of the percent change per minute of insulin?

Score 0 No response or the response does not address the prompt

Score 1 Fulfills only 1 of 2 requirements of a level 2 performance

Score 2 Calculates a number for the units of insulin at $t = 0$ that fits with the data; calculates an absolute value for the percent change that fits the data

2. A geologist is analyzing the erosion of a coastline over the past five years. The table below shows the relationship.

Time (years)	1	2	3	4	5
Cumulative Erosion (feet)	1.01	2.81	6.51	10.14	16.32

- Does a linear, exponential, or power function best fit the data? Explain.
- Write the equation of the function that best models the data.
- Using the equation created, how much erosion can be expected after 8 years?

Score 0 No response or the response does not address the task

Score 1 Fulfills only 1 of 3 requirements of a level 3 performance

Score 2 Fulfills 2 of 3 requirements of a level 3 performance

Score 3 Indicates the type of function that best models the data and explains its meaning; writes an equation that best models the data; calculates the amount of erosion expected after 8 years using the written equation



3. A restaurant determined that the calories of its meals are normally distributed. The mean is 680 calories with a standard deviation of 63 calories.

- Give a range of calories, centered on the mean, that includes 95% of the restaurant's meals.
- The cook creates a meal with 617 calories. What percentage of meals has more calories than this meal?

Score 0 No response or the response does not address the prompt

Score 1 Fulfills only 1 of 2 requirements of a level 2 performance

Score 2 Determines a range of calories centered around the mean that 95% of the meals will fall in; determines the percentage of meals that contain more than 617 calories

Released Fall 2012



4. The table below shows the cumulative frequency of student achievement scores for a particular class.

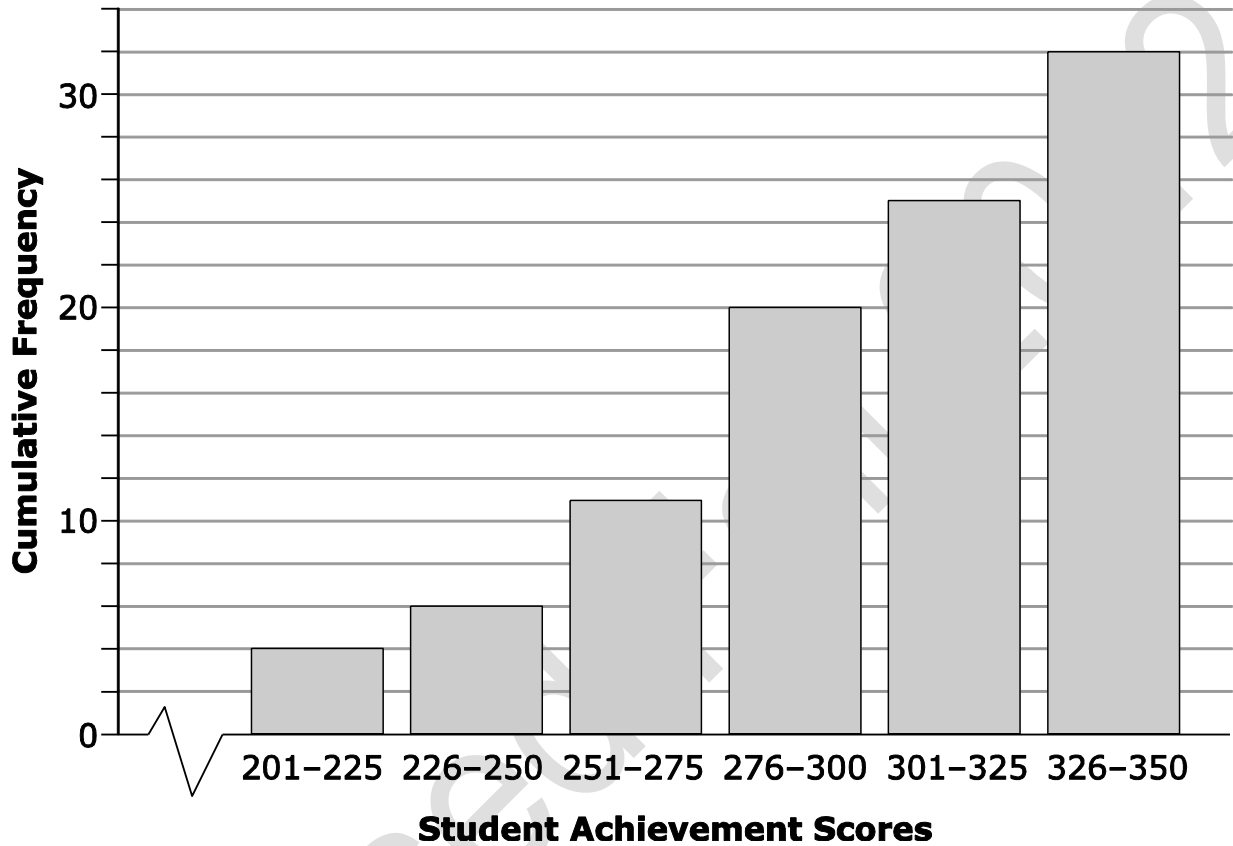

- Which 25-point interval contains the median achievement score?
- How many students scored at least a 276 on the achievement test?

Score 0 No response or the response does not address the prompt

Score 1 Fulfills only 1 of 2 requirements of a level 2 performance

Score 2 Identifies an interval that contains the median of the data; determines how many students scored at least 276 points



5. A professor of a statistics class has the following scores for her students: 296, 332, 290, 308, 343, 371, 336, 384, 361, 350.

- If 10 points are added to each score, what is the new mean and standard deviation?

Score 0 No response or the response does not address the prompt

Score 1 Determines the mean OR standard deviation for the new data

Score 2 Determines the mean AND standard deviation for the new data

6. Use the piecewise function below to answer each question.

$$h(x) = \begin{cases} -2x^2 + 5x + 10 & \text{for } -4 \leq x < 3 & \text{Step 1} \\ 3x + 2 & \text{for } 3 \leq x < 7 & \text{Step 2} \\ \sqrt{2x - 5} & \text{for } 7 \leq x < 16 & \text{Step 3} \end{cases}$$

- What is the range for step 1?
- What is the domain for the entire function?
- What is $h(10.5)$?

Score 0 No response or the response does not address the prompt

Score 1 Fulfills 1 of 3 requirements of a level 3 performance

Score 2 Fulfills 2 of 3 requirements of a level 3 performance

Score 3 Determines the range for step 1; determines the domain for the entire function; calculates the value of $h(10.5)$



7. For the following problem, round each answer to the nearest hundredth.

- Write the equation of the power function that passes through the points (1, 6) and (3, 14).
- Based on the above function, what is the value of x when $y = 8$?

Score 0 No response or the response does not address the prompt

Score 1 Fulfills only 1 of 2 requirements of a level 2 performance

Score 2 Provides an equation for the power function that passes through the points given; calculates a value for x when $y = 8$ using the written equation

8. Power functions can be written in the form $f(x) = ax^b$, where $b > 1$.

- Write an equation for an odd, positive-integer power function of this form.
- Graph the equation including enough of the domain to show the graph's important features.

Score 0 No response or the response does not address the prompt

Score 1 Fulfills only 1 of 2 requirements of a level 2 performance

Score 2 Writes an equation for an odd, positive-integer power function; graphs an image of the chosen function

APPENDIX TO CONSTRUCTED RESPONSE KEY ADVANCED FUNCTIONS AND MODELING



QID	Discrete Answers for Student Responses (* Student answers may vary.)
1	Score Point 1: * Score Point 2: *
2	Score Point 1: power function with explanation from student Score Point 2: * Score Point 3: *
3	Score Point 1: 554 calories to 806 calories Score Point 2: 84%
4	Score Point 1: 276–300 interval Score Point 2: 21 students
5	Score Point 1: mean score of 347.1 Score Point 2: standard deviation of 31.5
6	Score Point 1: [-42, 13.125] Score Point 2: [-4, 16) Score Point 3: 4
7	Score Point 1: * Score Point 2: *
8	Score Point 1: * Score Point 2: *

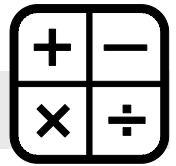

The questions you read next will require you to answer in writing.

1. Write your answers on separate paper.
2. Be sure to write your name on each page.

- 1 A farmer has 600 yards of fence. He will use some of the fence to enclose a rectangular area. He will use the rest to divide the area into two congruent rectangles, as shown below.

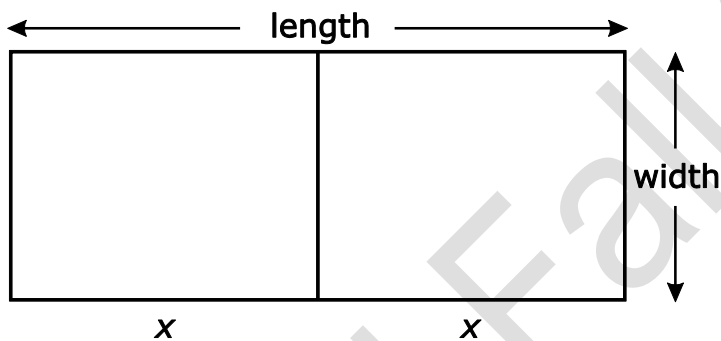

- What is the value of x that results in the largest area?
- What is the largest area that the farmer can enclose?
- What are the length and the width of the outer fence that will produce the largest total area?

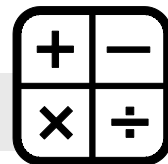

- 2 Suppose that Kyle has \$1,500 to invest. His investment will earn an interest rate of 8.25% compounded continuously.
- To the nearest cent, what will be the value of Kyle's investment after 6 years?
 - To the nearest tenth, how long will it take for Kyle's investment to grow to \$3,000?
 - To the nearest tenth, what interest rate would be needed to triple Kyle's investment in 15 years?
- 3 The function $f(t) = 36(0.50)^{\frac{1}{5,730}t}$ models the amount of carbon-14, in mg, remaining in a sample t years after the year 1200.
- What amount of carbon-14 was present in the sample in the year 1200?
 - What is the meaning of the coefficient of t in the context of the problem?
- 4 An apple orchard puts 6 apples in each basket it sells. Each apple weighs within 5% of 8 ounces.
- Write a single inequality using absolute value that can be used to find the minimum total weight and the maximum total weight of the apples in each basket.
 - What are the minimum total weight and the maximum total weight of the apples in each basket?

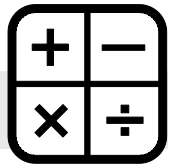

- 5 A company produces two types of bicycle tires: mountain bike tires and racing tires.
- I. The expected demand for mountain bike tires is at least 100 tires per week, and the expected demand for racing tires is at least 80 tires per week.
 - II. The company can produce no more than 200 mountain bike tires per week, and no more than 180 racing tires per week.
 - III. The company sells a maximum of 225 tires per week, and makes a net profit of \$5 per mountain bike tire and \$9 per racing tire.
- Write a system that models the constraints on bicycle tire production. Define the variables you use.
 - How many of each tire should the company produce in order to maximize profit?

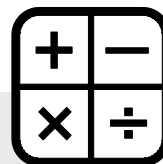

1. A farmer has 600 yards of fence. He will use some of the fence to enclose a rectangular area. He will use the rest to divide the area into two congruent rectangles, as shown below.

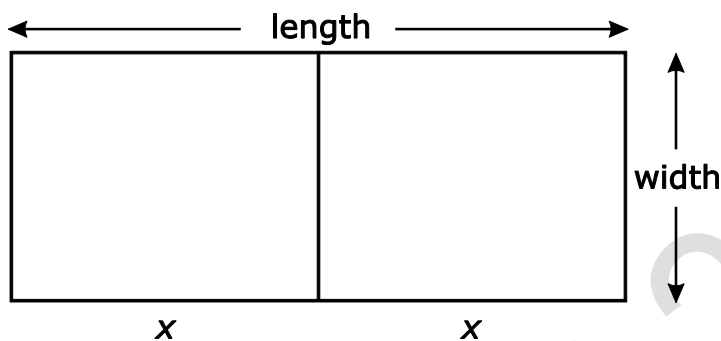

- What is the value of x that results in the largest area?
- What is the largest area that the farmer can enclose?
- What are the length and the width of the outer fence that will produce the largest total area?

Score 0 No response or the response does not address the prompt

Score 1 Fulfills only 1 of 3 requirements of a level 3 performance

Score 2 Fulfills 2 of 3 requirements of a level 3 performance

Score 3 Determines a value for x that results in the largest area; determines a value for the largest area enclosed; provides a value for the dimensions of the fence that will create the largest area

2. Suppose that Kyle has \$1,500 to invest. His investment will earn an interest rate of 8.25% compounded continuously.

- To the nearest cent, what will be the value of Kyle's investment after 6 years?
- To the nearest tenth, how long will it take for Kyle's investment to grow to \$3,000?
- To the nearest tenth, what interest rate would be needed to triple Kyle's investment in 15 years?

Score 0 No response or the response does not address the prompt

Score 1 Fulfills only 1 of 3 requirements of a level 3 performance

Score 2 Fulfills 2 of 3 requirements of a level 3 performance

Score 3 Determines a value for the investment after 6 years; determines how long it will take the investment to grow to \$3,000; determines the interest rate needed for the investment to triple in 15 years

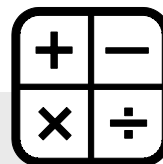

3. The function $f(t) = 36(0.50)^{\frac{1}{5,730}t}$ models the amount of carbon-14, in mg, remaining in a sample t years after the year 1200.

- What amount of carbon-14 was present in the sample in the year 1200?
- What is the meaning of the coefficient of t in the context of the problem?

Score 0 No response or the response does not address the prompt

Score 1 Fulfills only 1 of 2 requirements of a level 2 performance

Score 2 Identifies a value for the amount of carbon-14 present in year 1200; explains the meaning of the coefficient of t in the context of the problem

4. An apple orchard puts 6 apples in each basket it sells. Each apple weighs within 5% of 8 ounces.

- Write a single inequality using absolute value that can be used to find the minimum total weight and the maximum total weight of the apples in each basket.
- What are the minimum total weight and the maximum total weight of the apples in each basket?

Score 0 No response or the response does not address the prompt

Score 1 Fulfills only 1 of 2 requirements of a level 2 performance

Score 2 Provides an inequality that accurately models the scenario; determines the minimum and maximum weights for the baskets based on the written equation

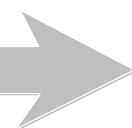

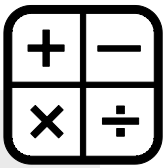

5. A company produces two types of bicycle tires: mountain bike tires and racing tires.
- IV. The expected demand for mountain bike tires is at least 100 tires per week, and the expected demand for racing tires is at least 80 tires per week.
 - V. The company can produce no more than 200 mountain bike tires per week, and no more than 180 racing tires per week.
 - VI. The company sells a maximum of 225 tires per week, and makes a net profit of \$5 per mountain bike tire and \$9 per racing tire.
- Write a system that models the constraints on bicycle tire production. Define the variables you use.
 - How many of each tire should the company produce in order to maximize profit?

Score 0 No response or the response does not address the prompt

Score 1 Fulfills only 1 of 2 requirements of a level 2 performance

Score 2 Writes a system of equations that models the constraints on tire production; determines a value for the number of each type of tire the company should produce to maximize profit

**APPENDIX TO CONSTRUCTED RESPONSE KEY
ALGEBRA II/INTEGRATED MATH III**

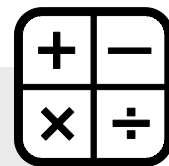

QID	Discrete Answers for Student Responses (* Student answers may vary.)
1	Score Point 1: 75 yards Score Point 2: 15,000 yards ² Score Point 3: length = 150 yards, width = 100 yards
2	Score Point 1: \$2,460.75 Score Point 2: 8.4 years Score Point 3: 7.3 %
3	Score Point 1: 36 mg Score Point 2: *
4	Score Point 1: * Score Point 2: *
5	Score Point 1: * Score Point 2: *



The questions you read next will require you to answer in writing.

1. Write your answers on separate paper.

2. Be sure to write your name on each page.

1 Circle M is shown below.

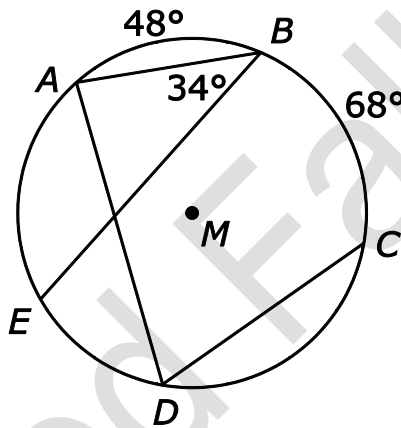

- What is the measure of $\angle ADC$?
- What is the measure of AE ?



2 In quadrilateral $ABCD$, $BD = 14$ cm.

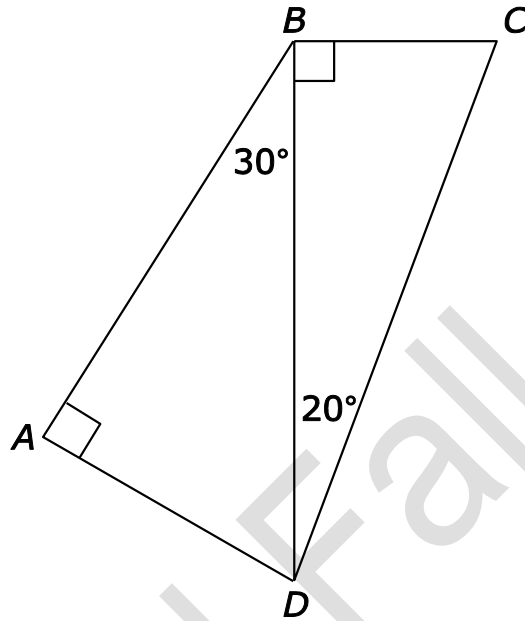

To the nearest tenth,

- What is the measure of \overline{AD} ?
- What is the measure of \overline{BC} ?
- What is the measure of \overline{CD} ?

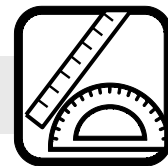

- 3 In the diagram below, $a \parallel b$.

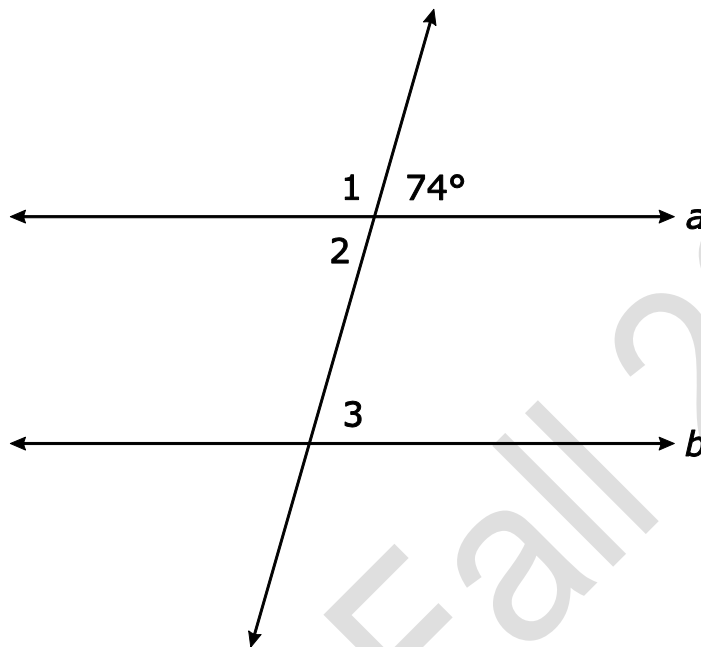

What are the measures of $\angle 1$, $\angle 2$, and $\angle 3$? Explain how each angle measure is determined.

- 4 In the diagram of $\triangle MNO$, \overline{NP} is drawn, $\angle MTP \cong \angle OTP$ and $\overline{MT} \cong \overline{OT}$.

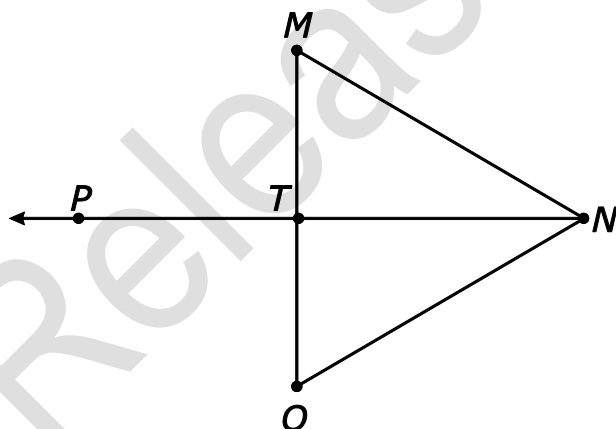

Using the diagram, write a proof showing that \overline{NT} bisects $\angle MNO$.



- 5 In the figure below, $\overline{MS} \cong \overline{MQ}$ and $\angle 1 \cong \angle 2$.

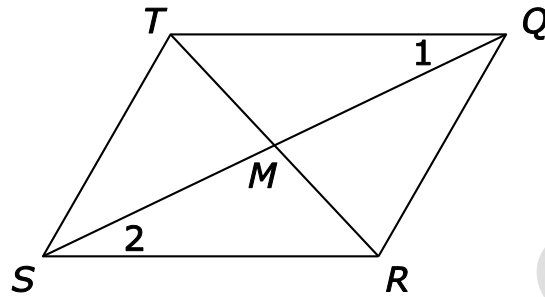

Based on the given facts, write a proof showing $QRST$ is a parallelogram.

Released Fall 2012



1. Circle M is shown below.

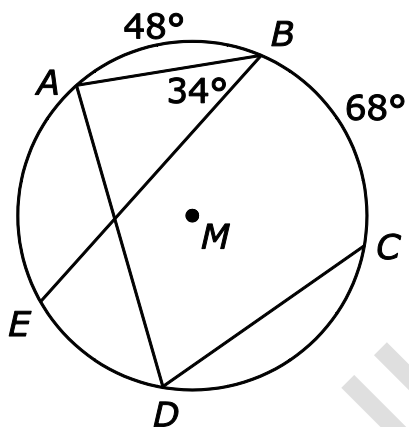

- What is the measure of $\angle ADC$?
- What is the measure of AE ?

Score 0 No response or the response does not address the prompt

Score 1 Fulfills only 1 of 2 requirements of a level 2 performance

Score 2 Determines a value for the measure of angle ADC ; determines a value for the measure of arc AE



2. In quadrilateral $ABCD$, $BD = 14$ cm.

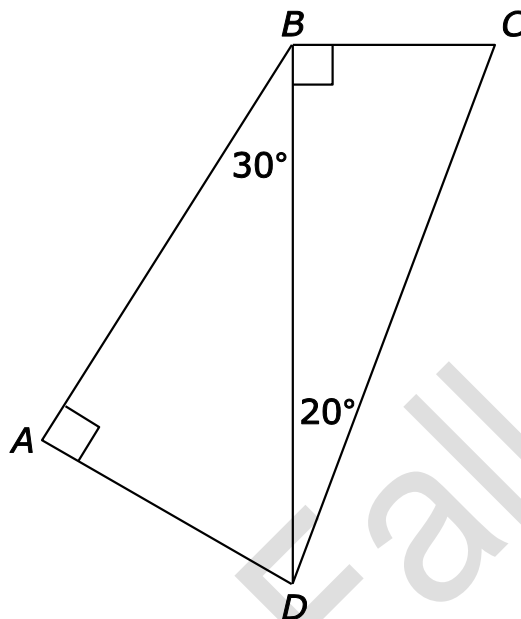

To the nearest tenth,

- What is the measure of \overline{AD} ?
- What is the measure of \overline{BC} ?
- What is the measure of \overline{CD} ?

Score 0 No response or the response does not address the prompt

Score 1 Fulfills only 1 of 3 requirements of a level 3 performance

Score 2 Fulfills 2 of 3 requirements of a level 3 performance

Score 3 Determines the length of line segment AD ; determines the length of line segment BC ; determines the length of line segment CD



3. In the diagram below, $a \parallel b$.

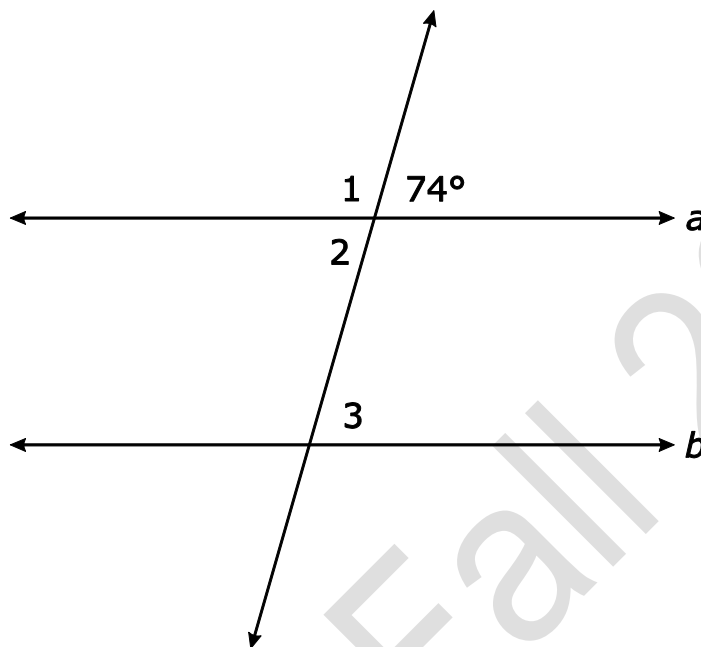

What are the measures of $\angle 1$, $\angle 2$, and $\angle 3$? Explain how each angle measure is determined.

- Score 0** No response or the response does not address the prompt
- Score 1** Fulfills only 1 of 3 requirements of a level 3 performance
- Score 2** Fulfills 2 of 3 requirements of a level 3 performance
- Score 3** Determines the measure of angle 1 and explains how it is determined; determines the measure of angle 2 and explains how it is determined; determines the measure of angle 3 and explains how it is determined



4. In the diagram of $\triangle MNO$, \overrightarrow{NP} is drawn, $\angle MTP \cong \angle OTP$ and $\overline{MT} \cong \overline{OT}$.

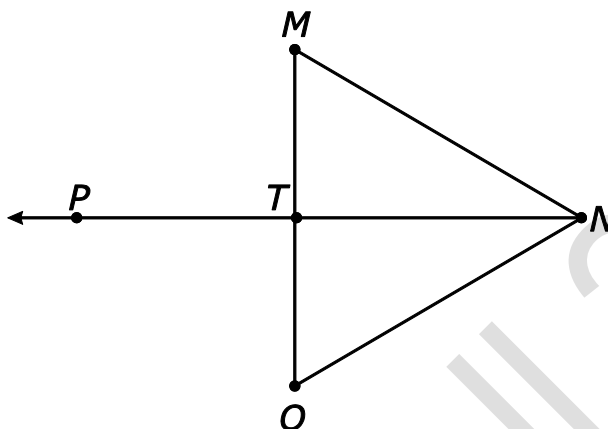

Using the diagram, write a proof showing that \overline{NT} bisects $\angle MNO$.

Score 0 No response or the response does not address the prompt

Score 1 Fulfills only 1 of 3 requirements of a level 3 performance

Score 2 Fulfills 2 of 3 requirements of a level 3 performance

Score 3 Provides a complete proof which includes logical steps with accurate notation and wording of theorems, postulates, etc.; includes relevant, correct statements and reasons; sequences statements logically and aligns reasons accurately to their statements

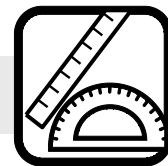

5. In the figure below, $\overline{MS} \cong \overline{MQ}$ and $\angle 1 \cong \angle 2$.

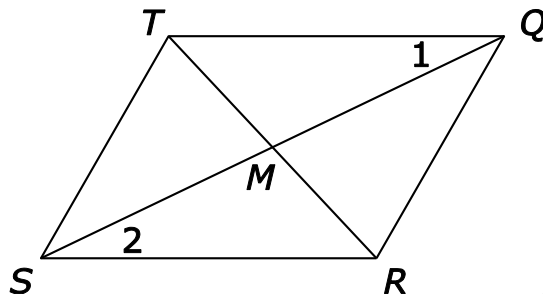

Based on the given facts, write a proof showing $QRST$ is a parallelogram.

- Score 0** No response or the response does not address the prompt
- Score 1** Fulfills only 1 of 3 requirements of a level 3 performance
- Score 2** Fulfills 2 of 3 requirements of a level 3 performance
- Score 3** Provides a complete proof, which includes logical steps with accurate notation and wording of theorems, postulates, etc.; includes relevant, correct statements and reasons; sequences statements logically and aligns reasons accurately to their statements

APPENDIX TO CONSTRUCTED RESPONSE KEY GEOMETRY

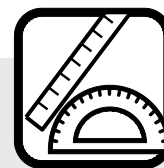

QID	Discrete Answers for Student Responses (* Student answers may vary.)
1	Score Point 1: 58° Score Point 2: 68°
2	Score Point 1: 7.0 cm Score Point 2: 5.1° or any equivalent/rounded value Score Point 3: 14.9° or any equivalent/rounded value
3	Score Point 1: 106° Score Point 2: 74° Score Point 3: 74°
4	Score Point 1: * Score Point 2: * Score Point 3: *
5	Score Point 1: * Score Point 2: * Score Point 3: *

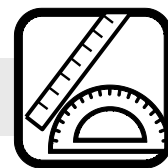

The questions you read next will require you to answer in writing.

- Write your answers on separate paper.
- Be sure to write your name on each page.

1 The general equation of an ellipse is shown below.

$$9x^2 - 54x + 25y^2 - 100y - 44 = 0$$

- Write an equivalent standard equation for the ellipse.
- Describe what the coefficients of x^2 and y^2 in the standard equation tell about this ellipse.

2 A child is pulling a sled through the snow with a force of 20 Newtons at an angle of 40° .

- To the nearest tenth, what is the vertical component of the force?
- To the nearest tenth, what is the horizontal component of the force?

3 The function $P(t) = 300e^{(0.038t)}$ models the number of bacteria in a population after t minutes.

- What is the meaning of the coefficient of e in the context of the problem?
- What is the meaning of the coefficient of t in the context of the problem?



PRE-CALCULUS

- 4 A person is on a ride at a carnival. The table below shows approximately how high the person is off the ground after t seconds.

Seconds (t)	Feet off the Ground (h)
0	3
10	14
20	25
30	33
40	25
50	14
60	3

- Write an equation of the sine function that **best** fits the data.
 - What is the meaning of the constant term in the equation you derived?
- 5 Scientists estimated the number of mosquitoes living in an area in different years.

Year	Mosquitoes (in thousands)
1960	6
1970	8
1980	12
1990	18
2000	34
2010	42

The scientists then decided to use an exponential best-fit model to predict the number of mosquitoes that will be in the area in 2020.

- Write an equation that the scientists used to make their prediction.
- Use your equation to predict how many mosquitoes will be living in the area in 2020?



- 6 A window maker uses the graph of a rose curve to create a pattern in stained glass.
- If the window maker uses the equation $r = 8\cos 4\theta$ to represent the curve, what is the maximum petal length?
 - How many petals does the graph have?
 - Explain your answers.
- 7 After driving 30 minutes at a constant rate, a mailman is 200 miles from his home. After 75 minutes, he is 150 miles from his home.
- Write a set of parametric equations that represent the mailman's distance from home over time.
- 8 Let $f(x) = 4^x$.
- Graph $f(x - 2) + 3$.
 - Write a description of the transformation that occurred.



1. The general equation of an ellipse is shown below.

$$9x^2 - 54x + 25y^2 - 100y - 44 = 0$$

- Write an equivalent standard equation for the ellipse.
- Describe what the coefficients of x^2 and y^2 in the standard equation tell about this ellipse.

Score 0 No response or the response does not address the prompt

Score 1 Fulfills only 1 of 2 requirements of a level 2 performance

Score 2 Writes an equation for the standard version of the ellipse given; provides a description of the meaning of the coefficient of x^2 and y^2 in the standard equation written

2. A child is pulling a sled through the snow with a force of 20 Newtons at an angle of 40° .

- To the nearest tenth, what is the vertical component of the force?
- To the nearest tenth, what is the horizontal component of the force?

Score 0 No response or the response does not address the prompt

Score 1 Fulfills only 1 of 2 requirements of a level 2 performance

Score 2 Calculates the vertical component of the force given; calculates the horizontal component of the force given

3. The function $P(t) = 300e^{(0.038t)}$ models the number of bacteria in a population after t minutes.

- What is the meaning of the coefficient of e in the context of the problem?
- What is the meaning of the coefficient of t in the context of the problem?

Score 0 No response or the response does not address the prompt

Score 1 Fulfills only 1 of 2 requirements of a level 2 performance

Score 2 Explains in context the meaning of the coefficient of e ; explains in context the meaning of the coefficient of t



4. A person is on a ride at a carnival. The table below shows approximately how high the person is off the ground after t seconds.

Seconds (t)	Feet off the Ground (h)
0	3
10	14
20	25
30	33
40	25
50	14
60	3

- Write an equation of the sine function that **best** fits the data.
- What is the meaning of the constant term in the equation you derived?

Score 0 No response or the response does not address the prompt

Score 1 Fulfills only 1 of 2 requirements of a level 2 performance

Score 2 Writes a sine function that best fits the data; describes the meaning of the constant in the written equation



5. Scientists estimated the number of mosquitoes living in an area in different years.

Year	Mosquitoes (in thousands)
1960	6
1970	8
1980	12
1990	18
2000	34
2010	42

The scientists then decided to use an exponential best-fit model to predict the number of mosquitoes that will be in the area in 2020.

- Write an equation that the scientists used to make their prediction.
- Use your equation to predict how many mosquitoes will be living in the area in 2020?

Score 0 No response or the response does not address the prompt

Score 1 Fulfills only 1 of 2 requirements of a level 2 performance

Score 2 Writes an exponential best-fit equation for the data; predicts the number of mosquitoes living in the area in 2020 using the model

6. A window maker uses the graph of a rose curve to create a pattern in stained glass.

- If the window maker uses the equation $r = 8 \cos 4\theta$ to represent the curve, what is the maximum petal length?
- How many petals does the graph have?
- Explain your answers.

Score 0 No response or the response does not address the prompt

Score 1 Fulfills only 1 of 2 requirements of a level 2 performance

Score 2 Calculates and explains what the petal length for the graph is; calculates and explains how many petals are created by the graph of the rose curve



7. After driving 30 minutes at a constant rate, a mailman is 200 miles from his home. After 75 minutes, he is 150 miles from his home.

- Write a set of parametric equations that represent the mailman's distance from home over time.

Score 0 No response or the response does not address the prompt

Score 1 Fulfills only 1 of 2 requirements of a level 2 performance

Score 2 Creates a 2-equation parametrization that represents the problem; uses correct coefficients and constants to model the mailman's route home

8. Let $f(x) = 4^x$.

- Graph $f(x - 2) + 3$.
- Write a description of the transformation that occurred.

Score 0 No response or the response does not address the prompt

Score 1 Fulfills only 1 of 2 requirements of a level 2 performance

Score 2 Graphs a correct transformation of the function; provides a correct description of the transformation that occurred

APPENDIX TO CONSTRUCTED RESPONSE KEY PRE-CALCULUS



QID	Discrete Answers for Student Responses (* Student answers may vary.)
1	Score Point 1: $\frac{(x-3)^2}{25} + \frac{(y-2)^2}{9} = 1$ Score Point 2: *
2	Score Point 1: 12.9° Score Point 2: 15.3°
3	Score Point 1: * Score Point 2: *
4	Score Point 1: * Score Point 2: *
5	Score Point 1: * Score Point 2: *
6	Score Point 1: 8 with student explanation Score Point 2: 8 with student explanation
7	Score Point 1: * Score Point 2: *
8	Score Point 1: * Score Point 2: shifted to the right 2 units and up 3 units



The selections used in the English Language Arts common exams are not released as these selections may be used in future common exams. Only the constructed response items are released.

The question you read next will require you to answer in writing.

- 1. Write your answer on separate paper.**
- 2. Be sure to write your name on each page.**

- 1 What effect is created by the chemist's interaction with the narrator at the end of the selection? Include one example from the text to support your answer.

The question you read next will require you to answer in writing.

- 1. Write your answer on separate paper.**
- 2. Be sure to write your name on each page.**

- 2 What global effect will be caused by continued deforestation? Include one example from the text to support your answer.

The question you read next will require you to answer in writing.

- 1. Write your answer on separate paper.**
- 2. Be sure to write your name on each page.**

- 3 Besides the title, what evidence is there to suggest that the poem is about improvement? Include one example from the text to support your answer.

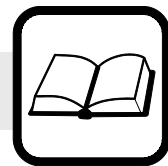

The question you read next will require you to answer in writing.

1. Write your answer on separate paper.
 2. Be sure to write your name on each page.
- 4 Determine the author's purpose for starting the selection with the quote, "When you get down to near death, it's amazing the clarity you get about what's really important and what is not," and analyze how the author's purpose is presented in the selection. Include two examples from the text to support your answer.

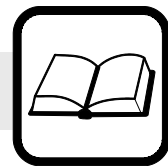

1. What effect is created by the chemist’s interaction with the narrator at the end of the selection? Include one example from the text to support your answer.

Score 0 No response or the response does not address the prompt

Score 1 Fulfills only 1 of 2 requirements for a level 2 performance

Score 2 Clearly and coherently identifies what effect is created by the chemist’s interaction with the narrator at the end of the selection;
Supports answer with one relevant example from the text

2. What global effect will be caused by continued deforestation? Include one example from the text to support your answer.

Score 0 No response or the response does not address the prompt

Score 1 Fulfills 1 of 2 requirements of a level 2 performance

Score 2 Clearly and coherently identifies a global effect caused by continued deforestation;
Supports answer with one relevant example from the text

3. Besides the title, what evidence is there to suggest that the poem is about improvement? Include one example from the text to support your answer.

Score 0 No response or the response does not address the prompt

Score 1 Fulfills only 1 of 2 requirements of a level 2 performance

Score 2 Clearly and coherently identifies evidence that the poem is about improvement;
Supports answer with one relevant example from the text

4. Determine the author’s purpose for starting the selection with the quote, “When you get down to near death, it’s amazing the clarity you get about what’s really important and what is not,” and analyze how the author’s purpose is presented in the selection. Include two examples from the text to support your answer.

Score 0 No response or the response does not address the prompt

Score 1 Fulfills only 1 of 4 requirements of a level 4 performance

Score 2 Fulfills 2 of 4 requirements of a level 4 performance

Score 3 Fulfills 3 of 4 requirements of a level 4 performance

Score 4 Clearly and coherently identifies the author’s purpose for starting the selection with the quote;
Clearly and coherently analyzes how the author’s purpose is presented in the selection;
Supports answer with one relevant example from the text;
Supports answer with a second relevant example from the text



The selections used in the English Language Arts common exams are not released as these selections may be used in future common exams. Only the constructed response items are released.

The question you read next will require you to answer in writing.

- 1. Write your answer on separate paper.**
- 2. Be sure to write your name on each page.**

- 1 What claim is the author making through his comparison of men and women in this selection? Include one example from the text to support your answer.

The question you read next will require you to answer in writing.

- 1. Write your answer on separate paper.**
- 2. Be sure to write your name on each page.**

- 2 Based on the text, how does the anecdote about truckers [REDACTED] and [REDACTED] contribute to the selection as a whole? Include one example from the text to support your answer.

The question you read next will require you to answer in writing.

- 1. Write your answer on separate paper.**
- 2. Be sure to write your name on each page.**

- 3 Based on the poem, how does the poet's use of figurative language in the first lines impact its meaning? Include one example from the text to support your answer.



The question you read next will require you to answer in writing.

1. Write your answer on separate paper.
 2. Be sure to write your name on each page.
- 4 Identify the author's claim and explain how it is refined within the selection. Analyze how the author addresses any counterclaims in the text. Include two examples from the text to support your answer.

Released Fall 2012



1. What claim is the author making through his comparison of men and women in this selection? Include one example from the text to support your answer.

Score 0 No response or the response does not address the prompt

Score 1 Fulfills only 1 of 2 requirements of a level 2 performance

Score 2 Clearly and coherently identifies the claim the author is making through his comparison of men and women;
Supports answer with one relevant example from the text

2. Based on the text, how does the anecdote about truckers █████ and █████ contribute to the selection as a whole? Include one example from the text to support your answer.

Score 0 No response or the response does not address the prompt

Score 1 Fulfills only 1 of 2 requirements of a level 2 performance

Score 2 Clearly and coherently identifies how the anecdote about truckers Elaine and Casey contributes to the selection;
Supports answer with one relevant example from the text

3. Based on the poem, how does the poet's use of figurative language in the first lines impact its meaning? Include one example from the text to support your answer.

Score 0 No response or the response does not address the prompt

Score 1 Fulfills only 1 of 2 requirements of a level 2 performance

Score 2 Clearly and coherently explains how the poet's use of figurative language in the first lines impacts the meaning;
Supports answer with one relevant example from the text

4. Identify the author's claim and explain how it is refined within the selection. Analyze how the author addresses any counterclaims in the text. Include two examples from the text to support your answer.

Score 0 No response or the response does not address the prompt

Score 1 Fulfills only 1 of 4 requirements of a level 4 performance

Score 2 Fulfills 2 of 4 requirements of a level 4 performance

Score 3 Fulfills 3 of 4 requirements of a level 4 performance

Score 4 Clearly and coherently identifies the author's claim and explains how it is refined within the selection;
Analyzes how the author addresses any counterclaims;
Supports answer with one relevant example from the text;
Supports answer with a second relevant example from the text



The selections used in the English Language Arts common exams are not released as these selections may be used in future common exams. Only the constructed response items are released.

The question you read next will require you to answer in writing.

- 1. Write your answer on separate paper.**
- 2. Be sure to write your name on each page.**

- 1 Based on the sentence below from the first paragraph, how does the author's choice of words impact the meaning of the text? Include one example from the text to support your answer.

"Ultimately he became nothing, a delightful, ineffectual young man with a perfect profile and no profession."

The question you read next will require you to answer in writing.

- 1. Write your answer on separate paper.**
- 2. Be sure to write your name on each page.**

- 2 Based on the first paragraph, how is the idea of negotiating a treaty developed within the selection? Include one example from the text to support your answer.

The question you read next will require you to answer in writing.

- 1. Write your answer on separate paper.**
- 2. Be sure to write your name on each page.**

- 3 Which detail from the poem supports the development of the theme? Identify the theme. Include one example from the text to support your answer.



The question you read next will require you to answer in writing.

1. Write your answer on separate paper.
 2. Be sure to write your name on each page.
- 4 Based on the selection, identify the author's point of view. Explain how the author develops his points. Include two examples from the text to support your answer.

Released Fall 2012



The selections used in the English Language Arts common exams are not released as these selections may be used in future common exams. Only the constructed response items are released.

1. Based on the sentence below from the first paragraph, how does the author’s choice of words impact the meaning of the text? Include one example from the text to support your answer.

“Ultimately he became nothing, a delightful, ineffectual young man with a perfect profile and no profession.”

- Score 0** No response or the response does not address the prompt
- Score 1** Fulfills only 1 of 2 requirements of a level 2 performance
- Score 2** Clearly and coherently identifies how the author’s choice of words impacts the meaning of the text;
Supports answer with one relevant example from the text

2. Based on the first paragraph, how is the idea of negotiating a treaty developed within the selection? Include one example from the text to support your answer.

- Score 0** No response or the response does not address the prompt
- Score 1** Fulfills only 1 of 2 requirements of a level 2 performance
- Score 2** Clearly and coherently identifies how the idea of having a treaty developed throughout the selection;
Supports answer with one relevant example from the text

3. Which detail from the poem supports the development of the theme? Identify the theme. Include one example from the text to support your answer.

- Score 0** No response or the response does not address the prompt
- Score 1** Fulfills only 1 of 2 requirements of a level 2 performance
- Score 2** Clearly and coherently identifies the theme of the poem;
Supports answer with one relevant example from the text

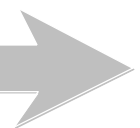



4. Based on the selection, identify the author’s point of view. Explain how the author develops his points. Include two examples from the text to support your answer.

Score 0 No response or the response does not address the prompt

Score 1 Fulfills only 1 of 4 requirements of a level 4 performance

Score 2 Fulfills 2 of 4 requirements of a level 4 performance

Score 3 Fulfills 3 of 4 requirements of a level 4 performance

Score 4 Clearly and coherently identifies the author’s point of view;
Clearly and coherently explains how the author develops his points;
Supports answer with one relevant example from the text;
Supports answer with a second relevant example from the text

Released Fall 2012





The questions you read next will require you to answer in writing.

1. Write your answers on separate paper.
2. Be sure to write your name on each page.

1 That on the first day of January, in the year of our Lord one thousand eight hundred and sixty-three, all persons held as slaves within any State or designated part of a State, the people whereof shall then be in rebellion against the United States, shall be then, thenceforward, and forever free; and the Executive Government of the United States, including the military and naval authority thereof, will recognize and maintain the freedom of such persons, and will do no act or acts to repress such persons, or any of them, in any efforts they may make for their actual freedom.

Abraham Lincoln, A Proclamation, January 1, 1863

Why is the issuance of Lincoln's Emancipation Proclamation a turning point in American history? Use one statement from the text as evidence to support your answer.

2 *This selection has been altered to use modern English spelling:*

We must be knit together, in this work, as one man. We must entertain each other in brotherly affection. We must be willing to abridge ourselves of our superfluities, for the supply of others' necessities. We must uphold a familiar commerce together in all meekness, gentleness, patience and liberality. We must delight in each other; make other's conditions our own; rejoice together, mourn together, labor and suffer together, always having before our eyes our commission and community in the work, as members of the same body. . . . The eyes of all people are upon us. So that if we shall deal falsely with our God in this work we have undertaken, and so cause him to withdraw his present help from us, we shall be made a story and a by-word through the world.

John Winthrop, *A Modell of Christian Charity*, 1630

How did religion influence settlement in colonial New England? Give one example from the selection to support your answer.

AMERICAN HISTORY I



- 3 In a response letter to John Holmes in April 1820 concerning the Missouri question, Thomas Jefferson wrote:

This momentous question, like a fire bell in the night, awakened and filled me with terror. I considered it at once as the [death] knell of the Union . . . but this is a reprieve only, not a final sentence. A geographical line, coinciding with a marked principle, moral and political, once conceived and held up to the angry passions of men, will never be obliterated; and every new irritation will mark it deeper and deeper . . . the cession of that kind of property . . . would not cost me in a second thought, if . . . a general emancipation . . . could be effected . . . but, as it is, we have the wolf by the ear, and we can neither hold him, nor safely let him go. Justice is in one scale, and self-preservation in the other.

Take a position on whether Jefferson believed that the Missouri Compromise was an effective resolution to the issue of territorial expansion. State your position and use one detail from the above letter as evidence to explain that position.

- 4 The Great rule of conduct for us, in regard to foreign nations is in extending our commercial relations to have with them as little political connection as possible . . . Europe has a set of primary interest, which to us have none, or a very remote relation . . . Why quit our own to stand upon foreign ground?—Why, by interweaving our destiny with that of any part of Europe, entangle our peace and prosperity in the toils of European ambition . . . Tis our true policy to steer clear of permanent alliances, with any portion of the foreign world.

President George Washington's Farewell Address, 1793

Use the excerpt above to explain how the Washington Administration affected U.S. foreign policy. Include two arguments from the excerpt to form your explanation.

- 5

Comparing the North and South

	North	South
Tariffs	supported protective tariffs	opposed protective tariffs
National Bank	avored a strong national bank	opposed a national bank

Explain how the two economic factors in the chart above contributed to sectional tension between the North and South in the decades before the Civil War. Use each factor to construct your explanation.

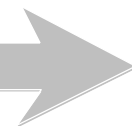



6 **British Actions After the French and Indian War**

- Navigation Acts
- Proclamation of 1763
- Stamp Act
- Writs of Assistance
- Townshend Acts

England exercised a policy of salutary neglect toward its colonies before the French and Indian War. Describe how the policy of salutary neglect was changed, and explain how it affected the British colonists as a result of two actions from the list above.

- 7 In the settlement of America we have to observe how European life entered the continent, and how [the American frontier] modified and developed that life . . . The frontier is the line of most rapid and effective Americanization. The wilderness masters the colonist. It finds him a European in dress, industries, tools, modes of travel, and thought . . . It strips off the garments of civilization and arrays him in the hunting shirt and the moccasin. . . He must accept the conditions which it furnishes, or perish. . . Little by little he transforms the wilderness, but the outcome is not the old Europe. . . The fact is, that here is a new product that is American. . . Thus the advance of the frontier has meant a steady movement away from the influence of Europe, a steady growth of independence on American lines. And to study this advance, the men who grew up under these conditions, and the political, economic, and social results of it, is to study the really American part of our history.

Frederick Jackson Turner

Extend Mr. Turner's essay by describing at least three American traits that the frontier encouraged. Provide an example from the essay to support each trait.



- 8 A republic, by which I mean a government in which the scheme of representation takes place, opens a different prospect, and promises the cure for which we are seeking . . . The two great points of difference between a democracy and a republic are: first, the delegation of the government, in the latter, to a small number of citizens elected by the rest; secondly, the greater number of citizens, and greater sphere of country, over which the latter may be extended. The effect of the first difference is . . . passing them through the medium of a chosen body of citizens, whose wisdom may discern the true interest of their country . . . On the other hand, the effect may be inverted. Men . . . of sinister designs, may, by intrigue, by corruption, or by other means, first obtain the suffrages, and then betray the interests, of the people. The question resulting is, whether small or extensive republics are more favorable to the election . . . In the first place, it is to be remarked that, however small the republic may be, the representatives must be raised to a certain number, in order to guard against . . . a few; and that, however large it may be, they must be limited to a certain number, in order to guard against the confusion of a multitude.

James Madison, The Federalist No. 10

Summarize James Madison's perspective on how the republican form of government as put forth in the Constitution would work by giving this excerpt a title. Support your title by stating three requirements for a republican government as found in the above text.

RUBRICS---AMERICAN HISTORY I



1. That on the first day of January, in the year of our Lord one thousand eight hundred and sixty-three, all persons held as slaves within any State or designated part of a State, the people whereof shall then be in rebellion against the United States, shall be then, thenceforward, and forever free; and the Executive Government of the United States, including the military and naval authority thereof, will recognize and maintain the freedom of such persons, and will do no act or acts to repress such persons, or any of them, in any efforts they may make for their actual freedom.

Abraham Lincoln, A Proclamation, January 1, 1863

Why is the issuance of Lincoln’s Emancipation Proclamation a turning point in American history? Use one statement from the text as evidence to support your answer.

- Score 0** No response or the response does not address the prompt
- Score 1** Fulfills only 1 of 2 requirements of a level 2 performance
- Score 2** Analyzes the role of the proclamation as a historic turning point; uses one statement from the text to support the analysis

2. *This selection has been altered to use modern English spelling:*

We must be knit together, in this work, as one man. We must entertain each other in brotherly affection. We must be willing to abridge ourselves of our superfluities, for the supply of others’ necessities. We must uphold a familiar commerce together in all meekness, gentleness, patience and liberality. We must delight in each other; make other’s conditions our own; rejoice together, mourn together, labor and suffer together, always having before our eyes our commission and community in the work, as members of the same body. . . . The eyes of all people are upon us. So that if we shall deal falsely with our God in this work we have undertaken, and so cause him to withdraw his present help from us, we shall be made a story and a by-word through the world.

John Winthrop, *A Modell of Christian Charity*, 1630

How did religion influence settlement in colonial New England? Give one example from the selection to support your answer.

- Score 0** No response or response does not address prompt
- Score 1** Fulfills only 1 of 2 requirements of a level 2 response
- Score 2** Analyzes the role of religion in colonial settlement of New England; supports analysis with one example from the passage



3. In a response letter to John Holmes in April 1820 concerning the Missouri question, Thomas Jefferson wrote:

This momentous question, like a fire bell in the night, awakened and filled me with terror. I considered it at once as the [death] knell of the Union . . . but this is a reprieve only, not a final sentence. A geographical line, coinciding with a marked principle, moral and political, once conceived and held up to the angry passions of men, will never be obliterated; and every new irritation will mark it deeper and deeper . . . the cession of that kind of property . . . would not cost me in a second thought, if . . . a general emancipation . . . could be effected . . . but, as it is, we have the wolf by the ear, and we can neither hold him, nor safely let him go. Justice is in one scale, and self-preservation in the other.

Take a position on whether Jefferson believed that the Missouri Compromise was an effective resolution to the issue of territorial expansion. State your position and use one detail from the above letter as evidence to explain that position.

- Score 0** No response or the response does not address the prompt
- Score 1** Fulfills only 1 of 2 requirements of a level 2 performance
- Score 2** States a position on Jefferson's belief; uses one detail from the letter to explain the position taken

4. The Great rule of conduct for us, in regard to foreign nations is in extending our commercial relations to have with them as little political connection as possible . . . Europe has a set of primary interest, which to us have none, or a very remote relation . . . Why quit our own to stand upon foreign ground?—Why, by interweaving our destiny with that of any part of Europe, entangle our peace and prosperity in the toils of European ambition . . . Tis our true policy to steer clear of permanent alliances, with any portion of the foreign world.

President George Washington's Farewell Address, 1793

Use the excerpt above to explain how the Washington Administration affected U.S. foreign policy. Include two arguments from the excerpt to form your explanation.

- Score 0** No response or the response does not address the prompt
- Score 1** Fulfills only 1 of 2 requirements of a level 2 performance
- Score 2** Explains how the Washington Administration affected U.S. foreign policy using one argument from the excerpt; explains using a second argument from the excerpt



5.

Comparing the North and South

	North	South
Tariff	supported protective tariffs	opposed protective tariffs
National Bank	favored a strong national bank	opposed a national bank

Explain how the two economic factors in the chart above contributed to sectional tension between the North and South in the decades before the Civil War. Use each factor to construct your explanation.

- Score 0** No response or the response does not address the prompt
- Score 1** Fulfills only 1 of 2 requirements of a level 2 performance
- Score 2** Explains sectional tension between the North and South using one economic factor from the chart; explains sectional tension using a second economic factor from the chart

6. **British Actions After the French and Indian War**

- Navigation Acts
- Proclamation of 1763
- Stamp Act
- Writs of Assistance
- Townshend Acts

England exercised a policy of salutary neglect toward its colonies before the French and Indian War. Describe how the policy of salutary neglect was changed, and explain how it affected the British colonists as a result of two actions from the list above.

- Score 0** No response or the response does not address the prompt
- Score 1** Fulfills only 1 of 3 requirements of a level 3 performance
- Score 2** Fulfills 2 of 3 requirements of a level 3 performance
- Score 3** Describes how the policy changed; explains how the policy affected the colonists using one British action from the list; explains how the policy affected the colonists using a second British action from the list

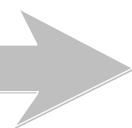



7. In the settlement of America we have to observe how European life entered the continent, and how [the American frontier] modified and developed that life . . . The frontier is the line of most rapid and effective Americanization. The wilderness masters the colonist. It finds him a European in dress, industries, tools, modes of travel, and thought . . . It strips off the garments of civilization and arrays him in the hunting shirt and the moccasin. . . He must accept the conditions which it furnishes, or perish. . . Little by little he transforms the wilderness, but the outcome is not the old Europe. . . The fact is, that here is a new product that is American. . . Thus the advance of the frontier has meant a steady movement away from the influence of Europe, a steady growth of independence on American lines. And to study this advance, the men who grew up under these conditions, and the political, economic, and social results of it, is to study the really American part of our history.

Frederick Jackson Turner

Extend Mr. Turner's essay by describing at least three American traits that the frontier encouraged. Provide an example from the essay to support each trait.

- Score 0** No response or the response does not address the prompt
- Score 1** Describes only 1 American trait; supports trait with an example from the essay
- Score 2** Describes 2 American traits; supports both traits with an example from the essay
- Score 3** Describes 3 American traits; supports each trait with an example from the essay



8. A republic, by which I mean a government in which the scheme of representation takes place, opens a different prospect, and promises the cure for which we are seeking . . . The two great points of difference between a democracy and a republic are: first, the delegation of the government, in the latter, to a small number of citizens elected by the rest; secondly, the greater number of citizens, and greater sphere of country, over which the latter may be extended. The effect of the first difference is . . . passing them through the medium of a chosen body of citizens, whose wisdom may discern the true interest of their country . . . On the other hand, the effect may be inverted. Men . . . of sinister designs, may, by intrigue, by corruption, or by other means, first obtain the suffrages, and then betray the interests, of the people. The question resulting is, whether small or extensive republics are more favorable to the election . . . In the first place, it is to be remarked that, however small the republic may be, the representatives must be raised to a certain number, in order to guard against . . . a few; and that, however large it may be, they must be limited to a certain number, in order to guard against the confusion of a multitude.

James Madison, The Federalist No. 10

Summarize James Madison’s perspective on how the republican form of government as put forth in the Constitution would work by giving this excerpt a title. Support your title by stating three requirements for a republican government as found in the above text.

- Score 0** No response or the response does not address the prompt
- Score 1** Fulfills only 1 of 4 requirements of a level 4 performance
- Score 2** Fulfills 2 of 4 requirements of a level 4 performance
- Score 3** Fulfills 3 of 4 requirements of a level 4 performance
- Score 4** Summarizes the excerpt with a title; states one requirement for republican government from the text; states a second requirement from the text; states a third requirement from the text

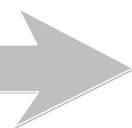

AMERICAN HISTORY II



The questions you read next will require you to answer in writing.

1. Write your answers on separate paper.
2. Be sure to write your name on each page.

- 1 The right of citizens of the United States to vote shall not be denied or abridged by the United States or by any State on account of sex.

Nineteenth Amendment to the Constitution

No person in the United States shall, on the basis of sex, be excluded from participation in, be denied the benefits of, or be subjected to discrimination under any education program or activity receiving Federal financial assistance. . . .

Title IX

The passage of the Nineteenth Amendment and Title IX legislation mark key turning points in United States history. Write a statement that evaluates the lasting impact of each upon gender equality in America.

- 2 Select an international conflict since World War II in which the United States was involved. Give two examples of how that conflict affected American society and culture.



- 3 We must make the Federal Government a friendly, vigilant defender of the rights and equalities of all Americans. And again I mean all Americans.

As Americans, we believe that every man should be free to live his life as he wishes. He should be limited only by his responsibility to his fellow countrymen. If this freedom is to be more than a dream, each man must be guaranteed equality of opportunity. The only limit to an American's achievement should be his ability, his industry, and his character. The rewards for his effort should be determined only by those truly relevant qualities.

Our immediate task is to remove the last remnants of the barriers which stand between millions of our citizens and their birthright. There is no justifiable reason for discrimination because of ancestry, or religion, or race, or color.

Harry S. Truman

President Truman's speech was inspired by the Civil Rights movement. How did this speech, and the movement, affect the country and its people? Analyze the role of this speech in the Civil Rights movement, and explain a strategy and a result of the movement.

- 4 Explain how a post-Reconstruction Supreme Court decision affected the distribution of power between the states and the national government. Include both the issue and the effect in your explanation.
- 5 State the impact of a cultural conflict of the 1960s on the United States. Summarize a resulting compromise.
- 6 Select a global war in which the United States was involved. Give two reasons why the United States entered the war, and explain the impact of that U.S. involvement on international affairs.



- 7 How did the Great Depression affect the United States during the first part of the twentieth century? Analyze two effects of the Great Depression on the national economy, and explain how the relationship between government and citizens was altered.
- 8 Select a group that immigrated to the United States since Reconstruction. Explain why that group migrated to the United States and settled in a particular region, how that group contributed to U.S. society, and one public or governmental response to that group's settlement in the United States.

RUBRICS---AMERICAN HISTORY II



1. The right of citizens of the United States to vote shall not be denied or abridged by the United States or by any State on account of sex.

Nineteenth Amendment to the Constitution

No person in the United States shall, on the basis of sex, be excluded from participation in, be denied the benefits of, or be subjected to discrimination under any education program or activity receiving Federal financial assistance. . . .

Title IX

The passage of the Nineteenth Amendment and Title IX legislation mark key turning points in United States history. Write a statement that evaluates the lasting impact of each upon gender equality in America.

Score 0 No response or the response does not address the prompt

Score 1 Fulfills only 1 of 2 requirements of a level 2 performance

Score 2 Evaluates the lasting impact of the Nineteenth Amendment on gender equality in the United States; evaluates the lasting impact of Title IX legislation on gender equality in the United States

2. Select an international conflict since World War II in which the United States was involved. Give two examples of how that conflict affected American society and culture.

Score 0 No response or the response does not address the prompt

Score 1 Fulfills only 1 of 2 requirements of a level 2 performance

Score 2 Provides one example of how an appropriate international conflict affected American society and culture; provides a second example of how that conflict affected American society and culture

RUBRICS---AMERICAN HISTORY II



3. We must make the Federal Government a friendly, vigilant defender of the rights and equalities of all Americans. And again I mean all Americans.

As Americans, we believe that every man should be free to live his life as he wishes. He should be limited only by his responsibility to his fellow countrymen. If this freedom is to be more than a dream, each man must be guaranteed equality of opportunity. The only limit to an American's achievement should be his ability, his industry, and his character. The rewards for his effort should be determined only by those truly relevant qualities.

Our immediate task is to remove the last remnants of the barriers which stand between millions of our citizens and their birthright. There is no justifiable reason for discrimination because of ancestry, or religion, or race, or color.

Harry S. Truman

President Truman's speech was inspired by the Civil Rights movement. How did this speech, and the movement, affect the country and its people? Analyze the role of this speech in the Civil Rights movement, and explain a strategy and a result of the movement.

- Score 0** No response or the response does not address the prompt
Score 1 Fulfills only 1 of 2 requirements of a level 2 performance
Score 2 Analyzes the speech by explaining a strategy; explains a result of the movement

4. Explain how a post-Reconstruction Supreme Court decision affected the distribution of power between the states and the national government. Include both the issue and the effect in your explanation.

- Score 0** No response or response does not address the prompt
Score 1 Fulfills only 1 of 2 requirements of a level 2 performance
Score 2 Describes the issue decided by a Supreme Court case; explains one effect of the case on the distribution of power

5. State the impact of a cultural conflict of the 1960s on the United States. Summarize a resulting compromise.

- Score 0** No response or the response does not address the prompt
Score 1 Fulfills only 1 of 2 requirements of a level 2 performance
Score 2 Analyzes the impact of a cultural conflict of the 1960s; summarizes a compromise that resulted from a cultural conflict of the 1960s

RUBRICS---AMERICAN HISTORY II



6. Select a global war in which the United States was involved. Give two reasons why the United States entered the war, and explain the impact of that U.S. involvement on international affairs.

- Score 0** No response or the response does not address the prompt
- Score 1** Fulfills only 1 of 3 requirements of a level 3 performance
- Score 2** Fulfills 2 of 3 requirements of a level 3 performance
- Score 3** Provides one reason for U.S. involvement in a global war; provides a second reason for U.S. involvement in a global war; explains the impact of that U.S. involvement on international affairs

7. How did the Great Depression affect the United States during the first part of the twentieth century? Analyze two effects of the Great Depression on the national economy, and explain how the relationship between government and citizens was altered.

- Score 0** No response or the response does not address the prompt
- Score 1** Fulfills only 1 of 3 requirements of a level 3 performance
- Score 2** Fulfills 2 of 3 requirements of a level 3 performance
- Score 3** Analyzes one economic effect of the Great Depression; analyzes a second effect of the Great Depression; explains how the relationship between government and citizens changed

8. Select a group that immigrated to the United States since Reconstruction.

Explain why that group migrated to the United States and settled in a particular region, how that group contributed to U.S. society, and one public or governmental response to that group's settlement in the United States.

- Score 0** No response or the response does not address the prompt
- Score 1** Fulfills only 1 of 4 requirements of a level 4 performance
- Score 2** Fulfills 2 of 4 requirements of a level 4 performance
- Score 3** Fulfills 3 of 4 requirements of a level 4 performance
- Score 4** Explains why a group immigrated to the United States; explains why a group settled in a particular region; explains how a group contributed to U.S. society; explains a governmental or social response to the group



The questions you read next will require you to answer in writing.

- 1. Write your answers on separate paper.**
- 2. Be sure to write your name on each page.**

- 1 John Locke, Thomas Hobbes, and Baron de Montesquieu were all important Enlightenment thinkers. Explain the philosophy of at least one of these thinkers and how his ideas contributed to the development of American government.
- 2 Explain how tensions between British governmental authority and the American colonists contributed to the American Revolution. Include a specific example in your response.
- 3 Choose a North Carolina industry and explain its importance in the national economy. Include two examples of that industry's global importance.



- 4 No government can exist without taxation. This money must necessarily be levied on the people; and the grand art consists of levying so as not to oppress.

Frederick the Great, eighteenth-century Prussian king

The power of taxing people and their property is essential to the very existence of government.

James Madison, U.S. President

Take a position that argues for or against the point of view of these statesmen. Explain your position by providing one specific example that supports your argument.

- 5 Establishing financial goals is an essential part of financial literacy. Explain how career and education can affect a person's financial future.

- 6 What role is fulfilled by automated transactions in checking and savings accounts? Give one example of an automated transaction that is a credit added to the account balance. Give a second example of an automated transaction that is a debit deducted from the account balance.

- 7 Throughout its history, American democracy has upheld and strengthened citizens' individual rights.

Take a position that argues for or against the above statement. Provide at least two specific historic examples (e.g., legislation, Supreme Court cases, executive orders, or other actions by the federal government) that support your position.



- 8 The level of competition within market economic systems affects prices and profits. Explain how:
1. competition affects profits
 2. competition affects prices
 3. profits and prices interact
 4. profits and prices may influence competition

Released Fall 2012

RUBRICS---CIVICS AND ECONOMICS



1. John Locke, Thomas Hobbes, and Baron de Montesquieu were all important Enlightenment thinkers. Explain the philosophy of at least one of these thinkers and how his ideas contributed to the development of American government.

Score 0	No response or the response does not address the prompt
Score 1	Fulfills only 1 of 2 requirements of a level 2 performance
Score 2	Explains the philosophy of one Enlightenment thinker; explains that thinker's contribution(s) to American government

2. Explain how tensions between British governmental authority and the American colonists contributed to the American Revolution. Include a specific example in your response.

Score 0	No response or the response does not address prompt
Score 1	Fulfills only 1 of 2 requirements of a level 2 performance
Score 2	Explains how distrust contributed to the American Revolution; includes one specific example of tension in the response

3. Choose a North Carolina industry and explain its importance in the national economy. Include two examples of that industry's global importance.

Score 0	No response or the response does not address the prompt
Score 1	Fulfills only 1 of 2 requirements of a level 2 performance
Score 2	Explains the importance of a N.C. industry to the nation's economy; provides 2 examples of that industry's global importance



4. No government can exist without taxation. This money must necessarily be levied on the people; and the grand art consists of levying so as not to oppress.

Frederick the Great, eighteenth-century Prussian king

The power of taxing people and their property is essential to the very existence of government.

James Madison, U.S. President

Take a position that argues for or against the point of view of these statesmen. Explain your position by providing one specific example that supports your argument.

- Score 0** No response or the response does not address the prompt
- Score 1** Fulfills only 1 of 2 requirements of a level 2 performance
- Score 2** Takes a position for or against the statesmen's point of view; provides one example that supports the argument

5. Establishing financial goals is an essential part of financial literacy. Explain how career and education can affect a person's financial future.

- Score 0** No response or the response does not address the prompt
- Score 1** Fulfills only 1 of 2 requirements of a level 2 performance
- Score 2** Explains how career can affect a person's financial future; explains how education can affect a person's financial future

6. What role is fulfilled by automated transactions in checking and savings accounts? Give one example of an automated transaction that is a credit added to the account balance. Give a second example of an automated transaction that is a debit deducted from the account balance.

- Score 0** No response or the response does not address the prompt
- Score 1** Fulfills only 1 of 3 requirements of a level 3 performance
- Score 2** Fulfills 2 of 3 requirements of a level 3 performance
- Score 3** Analyzes the role of automated transactions in checking and savings accounts; provides one example of an automated transaction that is a credit; provides one example of an automated transaction that is a debit

RUBRICS---CIVICS AND ECONOMICS



7. Throughout its history, American democracy has upheld and strengthened citizens' individual rights.

Take a position that argues for or against the above statement. Provide at least two specific historic examples (e.g., legislation, Supreme Court cases, executive orders, or other actions by the federal government) that support your position.

- Score 0** No response or the response does not address the prompt
- Score 1** Fulfills only 1 of 3 requirements of a level 3 performance
- Score 2** Fulfills 2 of 3 requirements of a level 3 performance
- Score 3** Takes a position that argues for or against the statement; provides one historic example that supports the position; provides a second historic example that supports the position

8. The level of competition within market economic systems affects prices and profits. Explain how:

1. competition affects profits
2. competition affects prices
3. profits and prices interact
4. profits and prices may influence competition

- Score 0** No response or the response does not address the prompt
- Score 1** Fulfills only 1 of 4 requirements of a level 4 performance
- Score 2** Fulfills 2 of 4 requirements of a level 4 performance
- Score 3** Fulfills 3 of 4 requirements of a level 4 performance
- Score 4** Explains how competition affects profits; explains how competition affects prices; explains how profits and prices interact; explains how profits and prices may influence competition



The questions you read next will require you to answer in writing.

1. Write your answers on separate paper.
2. Be sure to write your name on each page.

1 Owing to the centuries of division . . . the various parts of the country had developed differently. . . . This caused divergences not only in the spoken but in the written language. . . . Thus difficulties arose if, for instance, a man from the old territory of Ch'in [Qin] was to be transferred as an official to the east: he could not properly understand the language and could not read the borrowed words. . . . The government therefore ordered that the language of the whole country should be unified, and that a definite style of writing should be generally adopted. . . . In the various feudal states there had been different weights and measures in use, and this had led to great difficulties in the centralization of the collection of taxes. The centre of administration . . . had grown . . . into a thickly populated city with very large requirements of food. . . . The grain supplied in payment of taxation had to be brought in from far around, partly by cart. The only roads then existing consisted of deep cart-tracks. If the axles were not of the same length for all carts, the roads were simply unusable for many of them. Accordingly a fixed length was laid down for axles.

A History of China, Wolfram Eberhard

The Qin grew from a single city into a feudal state, and on to become the first imperial dynasty of China. Summarize the lasting impact of one achievement of the Qin Dynasty.



- 2 The Magna Carta was created after the rebellion of the Barons against King John of England, in which a change in government was demanded. Explain two specific ways the Magna Carta affected the structure of the British government.

- 3 Explain how one agricultural and one technological improvement changed daily life in Europe during the industrial and agricultural revolutions.

- 4 The Columbian Exchange accounts for the collapse of some nations and the great success of others. Explain one effect of the Columbian Exchange on American Indians. Explain one effect of the Columbian Exchange on Africans.

- 5 The Enlightenment was an intellectual, cultural, social, and philosophical movement that spread through Europe during the sixteenth century. Explain two effects of the Enlightenment on the world.

6

World Population Growth	
Year	World Population
1960	3 billion
2012	7 billion
+12 years	+1 billion

Explain three potential environmental consequences of the population growth indicated by the chart.



7 Twentieth-Century International Crises

- Berlin Blockade
- Korean War
- Hungarian Revolt
- Cuban Missile Crisis
- Iranian Revolt
- OPEC Oil Crisis

Choose a twentieth-century international crisis from the above list. Analyze the crisis and explain two specific effects it had on international politics.

8 Decolonized Nations:

- India
- Pakistan
- Kenya
- Ghana
- South Korea
- China
- Vietnam

The social and economic conditions of colonial rule contributed to the rise of nationalistic movements. Explain how an economic condition from the experiences of a country in the list above contributed to the rise of a nationalist movement. From the experience of another country in the list, explain how a social condition contributed to the rise of a nationalist movement.



1. Owing to the centuries of division . . . the various parts of the country had developed differently. . . . This caused divergences not only in the spoken but in the written language. . . . Thus difficulties arose if, for instance, a man from the old territory of Ch'in [Qin] was to be transferred as an official to the east: he could not properly understand the language and could not read the borrowed words. . . . The government therefore ordered that the language of the whole country should be unified, and that a definite style of writing should be generally adopted. . . .

In the various feudal states there had been different weights and measures in use, and this had led to great difficulties in the centralization of the collection of taxes. The centre of administration . . . had grown . . . into a thickly populated city with very large requirements of food. . . . The grain supplied in payment of taxation had to be brought in from far around, partly by cart. The only roads then existing consisted of deep cart-tracks. If the axles were not of the same length for all carts, the roads were simply unusable for many of them. Accordingly a fixed length was laid down for axles.

A History of China, Wolfram Eberhard

The Qin grew from a single city into a feudal state, and on to become the first imperial dynasty of China. Summarize the lasting impact of one achievement of the Qin Dynasty.

- Score 0** No response or the response does not address the prompt
- Score 1** Fulfills only 1 of 2 requirements of a level 2 performance
- Score 2** Differentiates an achievement of the Qin Dynasty; summarizes the lasting impact of one achievement of the Qin Dynasty

2. The Magna Carta was created after the rebellion of the Barons against King John of England, in which a change in government was demanded. Explain two specific ways the Magna Carta affected the structure of the British government.

- Score 0** No response or the response does not address the prompt
- Score 1** Fulfills only 1 of 2 requirements of a level 2 performance
- Score 2** Explains one structural change to British government from the Magna Carta; explains a second structural change to British government from the Magna Carta



3. Explain how one agricultural and one technological improvement changed daily life in Europe during the industrial and agricultural revolutions.

Score 0 No response or the response does not address the prompt

Score 1 Fulfills only 1 of 2 requirements of a level 2 performance

Score 2 Explains the impact of one agricultural improvement on European daily life; explains the impact of one technological improvement on European daily life

4. The Columbian Exchange accounts for the collapse of some nations and the great success of others. Explain one effect of the Columbian Exchange on American Indians. Explain one effect of the Columbian Exchange on Africans.

Score 0 No response or the response does not address the prompt

Score 1 Fulfills only 1 of 2 requirements of a level 2 performance

Score 2 Explains one effect of Columbian Exchange on American Indians; explains one effect of Columbian Exchange on Africans

5. The Enlightenment was an intellectual, cultural, social, and philosophical movement that spread through Europe during the sixteenth century. Explain two effects of the Enlightenment on the world.

Score 0 No response or the response does not address the prompt

Score 1 Fulfills only 1 of 2 requirements of a level 2 performance

Score 2 Explains one effect of the Enlightenment on the world; explains a second effect of the Enlightenment on the world



6.

World Population Growth	
Year	World Population
1960	3 billion
2012	7 billion
+12 years	+1 billion

Explain three potential environmental consequences of the population growth indicated by the chart.

- Score 0** No response or the response does not address the prompt
- Score 1** Fulfills only 1 of 3 requirements of a level 3 performance
- Score 2** Fulfills 2 of 3 requirements of a level 3 performance
- Score 3** Explains 1 potential environmental consequence of population growth; explains a second potential environmental consequence of population growth; explains a third potential environmental consequence of population growth

7. **Twentieth-Century International Crises**

- Berlin Blockade
- Korean War
- Hungarian Revolt
- Cuban Missile Crisis
- Iranian Revolt
- OPEC Oil Crisis

Choose a twentieth-century international crisis from the above list. Analyze the crisis and explain two specific effects it had on international politics.

- Score 0** No response or the response does not address the prompt
- Score 1** Fulfills only 1 of 3 requirements of a level 3 performance
- Score 2** Fulfills 2 of 3 requirements of a level 3 performance
- Score 3** Analyzes a crisis from the list; explains one effect on international politics; explains a second effect on international politics



8. Decolonized Nations:

- India
- Pakistan
- Kenya
- Ghana
- South Korea
- China
- Vietnam

The social and economic conditions of colonial rule contributed to the rise of nationalistic movements. Explain how an economic condition from the experiences of a country in the list above contributed to the rise of a nationalist movement. From the experience of another country in the list, explain how a social condition contributed to the rise of a nationalist movement.

Score 0 No response or response does not address the prompt

Score 1 Fulfills only 1 of 4 requirements of a level 4 performance

Score 2 Fulfills 2 of 4 requirements of a level 4 performance

Score 3 Fulfills 3 of 4 requirements of a level 4 performance

Score 4 Identifies an economic condition in a country from the list; explains how that economic condition gave rise to a nationalist movement; identifies a social condition in a second country from the list; explains how the social condition gave rise to a nationalist movement



The questions you read next will require you to answer in writing.

1. Write your answers on separate paper.
2. Be sure to write your name on each page.

- 1 Atomic size is one of many trends of the periodic table.
 - Describe one reason atomic size may vary among the elements of the periodic table.
 - List the correct order of aluminum, magnesium, phosphorus, silicon, sodium, and sulfur, based on decreasing atomic size.
- 2 During a laboratory experiment, 75 grams of water at 100°C is transformed into steam at 100°C.
 - Describe how this experiment confirms the law of conservation of energy.
 - How much heat energy is needed to completely change the state of the water? Show your work.
- 3 A compound contains the elements copper and chlorine in a ratio of 1 copper : 2 chlorine.
 - What is the empirical formula for this compound?
 - What is the percent composition of copper in this compound? Show your work.
 - What is the percent composition of chlorine in this compound? Show your work.



- 4 Acids are solutions with specific characteristics.
- Describe the chemical reaction which occurs between an acid and a metal.
 - If a ribbon of magnesium and hydrochloric acid were combined, which products would result in this chemical reaction?
- 5 A solution containing 12.9 g of MgCl_2 is dissolved in water to make a 0.54-L solution.
- What is the Molarity of the solution? Show your work.
 - Describe how decreasing the volume would affect the Molarity of the solution.



- Atomic size is one of many trends of the periodic table.
 - Describe one reason atomic size may vary among the elements of the periodic table.
 - List the correct order of aluminum, magnesium, phosphorus, silicon, sodium, and sulfur, based on decreasing atomic size.

- Score 0** No response or the response does not address the prompt
- Score 1** Fulfills only 1 of 2 requirements of a level 2 performance
- Score 2** Describes a reason atomic size varies on the periodic table; sequences the elements in order of decreasing atomic size

- During a laboratory experiment, 75 grams of water at 100°C is transformed into steam at 100°C.
 - Describe how this experiment confirms the law of conservation of energy.
 - How much heat energy is needed to completely change the state of the water? Show your work.

- Score 0** No response or the response does not address the prompt
- Score 1** Fulfills only 1 of 2 requirements of a level 2 performance
- Score 2** Describes how the experiment follows the law of conservation of energy; calculates the amount of heat energy transferred during the phase change

- A compound contains the elements copper and chlorine in a ratio of 1 copper : 2 chlorine.
 - What is the empirical formula for this compound?
 - What is the percent composition of copper in this compound? Show your work.
 - What is the percent composition of chlorine in this compound? Show your work.

- Score 0** No response or the response does not address the prompt
- Score 1** Fulfills only 1 of 3 requirements of a level 3 performance
- Score 2** Fulfills 2 of 3 requirements of a level 3 performance
- Score 3** Determines the empirical formula for copper and chlorine; calculates the percent composition of copper; calculates the percent composition of chlorine



4. Acids are solutions with specific characteristics.
- Describe the chemical reaction which occurs between an acid and a metal.
 - If a ribbon of magnesium and hydrochloric acid were combined, which products would result in this chemical reaction?

Score 0	No response or the response does not address the prompt
Score 1	Fulfills only 1 of 2 requirements of a level 2 performance
Score 2	Describes the chemical reaction between an acid and a metal; identifies the products of the chemical reaction between magnesium and hydrochloric acid

5. A solution containing 12.9 g of $MgCl_2$ is dissolved in water to make a 0.54-L solution.
- What is the Molarity of the solution? Show your work.
 - Describe how decreasing the volume would affect the Molarity of the solution.

Score 0	No response or the response does not address the prompt
Score 1	Fulfills only 1 of 2 requirements of a level 2 performance
Score 2	Calculates the Molarity of the solution; describes how decreasing the volume could affect the Molarity of the solution

APPENDIX TO CONSTRUCTED RESPONSE KEY CHEMISTRY

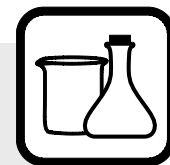

QID	Discrete Answers for Student Responses (* Student answers may vary.)
1	Score Point 1: * Score Point 2: Na, Mg, Al, Si, P, S
2	Score Point 1: * Score Point 2: 169,000 J
3	Score Point 1: CuCl_2 Score Point 2: 47 % Score Point 3: 53 %
4	Score Point 1: * Score Point 2: hydrogen gas (H_2) and magnesium chloride/salt (MgCl_2)
5	Score Point 1: 0.25 M Score Point 2: *



The questions you read next will require you to answer in writing.

1. Write your answers on separate paper.
2. Be sure to write your name on each page.

- 1 A weather map shows closely spaced isobar lines over an area.
 - What do the isobar lines represent?
 - What do the closely spaced isobars indicate about the weather in the area?
- 2 Volcanoes are a major geologic feature on Earth.
 - Describe the particles and gases emitted during a volcanic eruption.
 - Describe how a volcano can impact global climate.
- 3 Hydroelectric resources can be used to produce electricity in some areas of the country.
 - What is an advantage of using hydroelectric resources for power rather than using fossil fuel resources for power?
 - What is a disadvantage of using hydroelectric resources for the production of electricity?
- 4 Many farmers use conventional methods of growing crops.
 - What is one advantage of using conventional agricultural methods?
 - How can conventional agricultural methods impact the economy?



- 5 To conserve natural resources, people are encouraged to “reduce, reuse, recycle.”
- Identify one example of a material that could be reused.
 - How could reusing the object provide a lasting impact on the environment?

Released Fall 2012



1. A weather map shows closely spaced isobar lines over an area.

- What do the isobar lines represent?
- What do the closely spaced isobars indicate about the weather in the area?

Score 0 No response or the response does not address the prompt

Score 1 Fulfills only 1 of 2 requirements of a level 2 performance

Score 2 Explains what isobar lines represent; provides an accurate description of the weather associated with closely spaced isobars

2. Volcanoes are a major geologic feature on Earth.

- Describe the particles and gases emitted during a volcanic eruption.
- Describe how a volcano can impact global climate.

Score 0 No response or the response does not address the prompt

Score 1 Fulfills only 1 of 2 requirements of a level 2 performance

Score 2 Provides an accurate description of the particles and gases emitted from a volcanic eruption; provides an accurate description of how those particles can lead to global climate change

3. Hydroelectric resources can be used to produce electricity in some areas of the country.

- What is an advantage of using hydroelectric resources for power rather than using fossil fuel resources for power?
- What is a disadvantage of using hydroelectric resources for the production of electricity?

Score 0 No response or the response does not address the prompt

Score 1 Fulfills only 1 of 2 requirements of a level 2 performance

Score 2 Provides an advantage of using hydroelectric resources; provides a disadvantage of using hydroelectric resources



4. Many farmers use conventional methods of growing crops.

- What is one advantage of using conventional agricultural methods?
- How can conventional agricultural methods impact the economy?

Score 0 No response or the response does not address the prompt

Score 1 Fulfills only 1 of 2 requirements of a level 2 performance

Score 2 Provides an advantage for conventional agricultural methods; assesses the impact conventional agricultural methods have on the economy

5. To conserve natural resources, people are encouraged to “reduce, reuse, recycle.”

- Identify one example of a material that could be reused.
- How could reusing the object provide a lasting impact on the environment?

Score 0 No response or the response does not address the prompt

Score 1 Fulfills only 1 of 2 requirements of a level 2 performance

Score 2 Provides an example of an item that could be reused; assesses the lasting impact of reusing the item on the environment

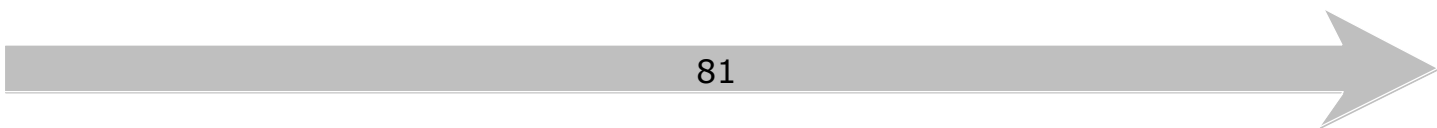

**APPENDIX TO CONSTRUCTED RESPONSE KEY
EARTH/ENVIRONMENTAL SCIENCE**



QID	Discrete Answers for Student Responses (* Student answers may vary.)
1	Score Point 1: * Score Point 2: *
2	Score Point 1: * Score Point 2: *
3	Score Point 1: * Score Point 2: *
4	Score Point 1: * Score Point 2: *
5	Score Point 1: * Score Point 2: *

Released Fall 2012

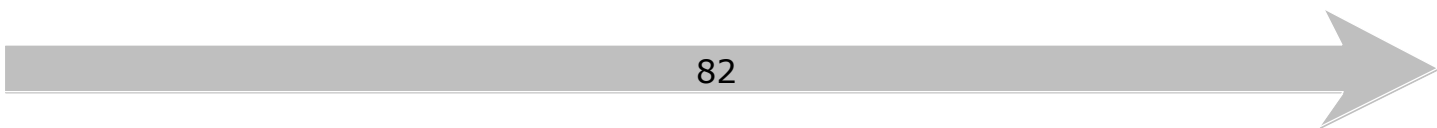

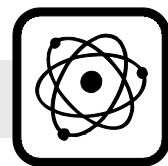

The questions you read next will require you to answer in writing.

1. Write your answers on separate paper.

2. Be sure to write your name on each page.

- 1 Describing an object's movement depends on the frame of reference that is being used.
 - What is a frame of reference?
 - Choose one object in the classroom and provide an example of how that object can be used as a frame of reference.

- 2 Matter changes from one state to another state during a phase change.
 - Explain how the processes of evaporation and boiling are similar.
 - Explain how the processes of evaporation and boiling are different.

- 3 A student is holding a stack of books.
 - Is the student doing any work on the books? Explain your answer.

- 4 A man wants to move a 200-N box a height of 4 meters, using a ramp that is 5 meters long.
 - What type of simple machine is the ramp?
 - Describe what happens to the input force now as a result of using the ramp to move the box.
 - Calculate the Ideal Mechanical Advantage (IMA) of the ramp. Show your work.

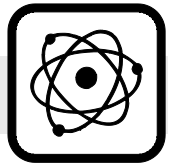

- 5 A wave has a frequency of 55 Hz and a speed of 35 m/s.
- What is the wavelength of the wave? Show your work.
 - If the frequency of the wave increases, what will happen to the wavelength?
- 6 A girl drops a penny in the shallow end of a swimming pool. As she bends down to pick up the penny, she realizes that the penny is farther away in the pool than it appears.
- Identify the wave behavior that is taking place.
 - How does the wave behavior cause the penny to appear closer than it actually is?

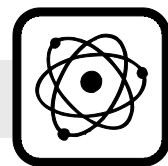

1. Describing an object's movement depends on the frame of reference that is being used.

- What is a frame of reference?
- Choose one object in the classroom and provide an example of how that object can be used as a frame of reference.

Score 0 No response or the response does not address the prompt

Score 1 Fulfills only 1 of 3 requirements of a level 3 performance

Score 2 Fulfills 2 of 3 requirements of a level 3 performance

Score 3 Describes frame of reference; identifies an example that can be used as a frame of reference; provides an example of how the object can be used as a frame of reference

2. Matter changes from one state to another state during a phase change.

- Explain how the processes of evaporation and boiling are similar.
- Explain how the processes of evaporation and boiling are different.

Score 0 No response or the response does not address the prompt

Score 1 Fulfills only 1 of 2 requirements of a level 2 performance

Score 2 Provides an explanation for how evaporation and boiling are similar; provides an explanation for how evaporation and boiling are different

3. A student is holding a stack of books.

- Is the student doing any work on the books? Explain your answer.

Score 0 No response or the response does not address the prompt

Score 1 Fulfills only 1 of 2 requirements of a level 2 performance

Score 2 Determines if the student is performing work; explains valid reason for answer

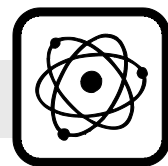

4. A man wants to move a 200-N box a height of 4 meters, using a ramp that is 5 meters long.

- What type of simple machine is the ramp?
- Describe what happens to the input force now as a result of using the ramp to move the box.
- Calculate the Ideal Mechanical Advantage (IMA) of the ramp. Show your work.

Score 0 No response or the response does not address the prompt

Score 1 Fulfills only 1 of 3 requirements of a level 3 performance

Score 2 Fulfills 2 of 3 requirements of a level 3 performance

Score 3 Identifies an accurate type of simple machine associated with the ramp; provides an accurate description of how the input force is impacted by using a ramp; calculates an accurate value for the IMA of the inclined plane (ramp)

5. A wave has a frequency of 55 Hz and a speed of 35 m/s.

- What is the wavelength of the wave? Show your work.
- If the frequency of the wave increases, what will happen to the wavelength?

Score 0 No response or the response does not address the prompt

Score 1 Fulfills only 1 of 2 requirements of a level 2 performance

Score 2 Calculates the wavelength of the wave; describes the change in wavelength as frequency increases

6. A girl drops a penny in the shallow end of a swimming pool. As she bends down to pick up the penny, she realizes that the penny is farther away in the pool than it appears.

- Identify the wave behavior that is taking place.
- How does the wave behavior cause the penny to appear closer than it actually is?

Score 0 No response or the response does not address the prompt

Score 1 Fulfills only 1 of 2 requirements of a level 2 performance

Score 2 Identifies the wave behavior that causes light waves to bend; provides an explanation of refraction

APPENDIX TO CONSTRUCTED RESPONSE KEY PHYSICAL SCIENCE

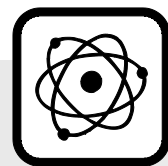

QID	Discrete Answers for Student Responses (* Student answers may vary.)
1	Score Point 1: * Score Point 2: * Score Point 3: *
2	Score Point 1: * Score Point 2: *
3	Score Point 1: No Score Point 2: *
4	Score Point 1: inclined plane Score Point 2: * Score Point 3: 1.25
5	Score Point 1: 0.64 m Score Point 2: *
6	Score Point 1: refraction Score Point 2: *

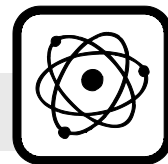

The questions you read next will require you to answer in writing.

1. Write your answers on separate paper.
2. Be sure to write your name on each page.

- 1 This diagram represents a DC circuit. Using the information in the circuit diagram, answer the questions below.

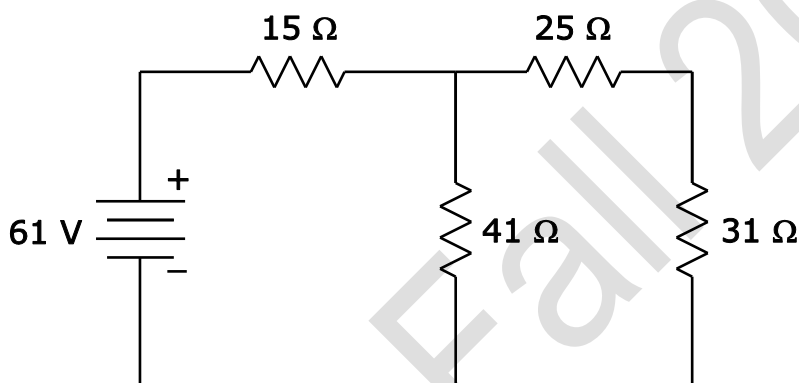

- What is the total resistance of the circuit? Show your work.
- How much total current is flowing through the circuit? Show your work.
- If the 41-Ω resistor seems to be producing a different amount of resistance than 41 Ω, what should be done to verify this?

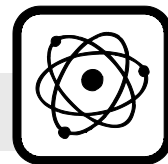

- 2 An object is projected with a velocity of 12.0 m/s at an angle 30.0° above the horizontal. Ignore air resistance.

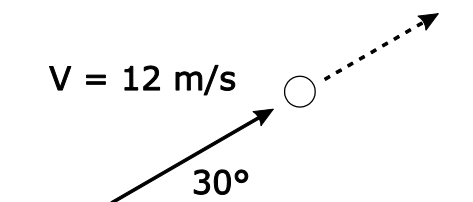

- What are the horizontal and vertical components of the initial velocity of the object? Show your work.
 - What distance does the object travel in the vertical direction? Show your work.
- 3 A force of 18 N parallel to the ground pulls on a 4.8-kg box, but the box remains at rest.
- What is the frictional force acting on the box? Show your work.
 - Draw and label a free-body diagram to explain your answer.
- 4 After applying a braking force of 290 N, the speed of a 115-kg motorcycle decreased from 45 m/s to 30 m/s.
- How much time did it take for the motorcycle to decrease its speed to 30 m/s? Explain your answer.
 - Explain, using Newton's laws of motion, why decreasing the speed of a moving object is not instantaneous.

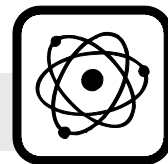

- 5 A horizontal force acts on a block, making it slide on a horizontal surface. The force of friction between the block and the surface is 0.5 N.

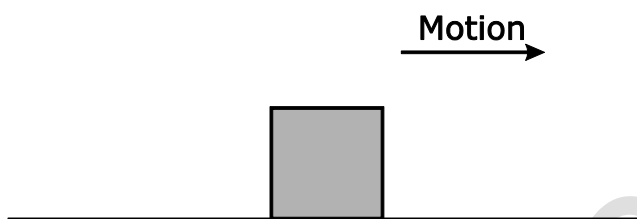

- If the direction of the applied initial force causing the block to slide is reversed, how will this affect the force of friction on the block? Explain your answer.
- How will reversing the initial force affect the net force on the block? Explain your answer.
- How will reversing the initial force affect the acceleration of the block? Explain your answer.

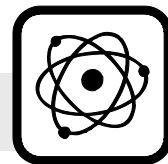

1. This diagram represents a DC circuit. Using the information in the circuit diagram, answer the questions below.

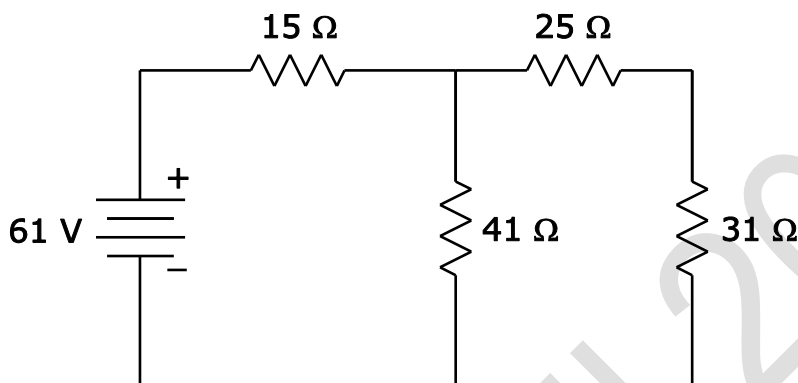

- What is the total resistance of the circuit? Show your work.
- How much total current is flowing through the circuit? Show your work.
- If the 41- Ω resistor seems to be producing a different amount of resistance than 41 Ω , what should be done to verify this?

Score 0 No response or the response does not address the prompt

Score 1 Fulfills only 1 of 2 requirements of a level 3 performance

Score 2 Fulfills 2 of 3 requirements of a level 3 performance

Score 3 Calculates the circuit's total resistance; calculates the amount of current flowing through the circuit; describes a way to determine the status of the 41- Ω resistor

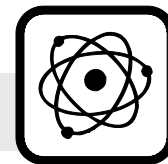

2. An object is projected with a velocity of 12.0 m/s at an angle 30.0° above the horizontal. Ignore air resistance.

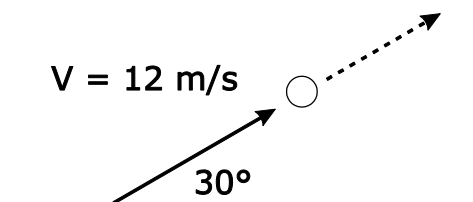

- What are the horizontal and vertical components of the initial velocity of the object? Show your work.
- What distance does the object travel in the vertical direction? Show your work.

Score 0	No response or the response does not address the prompt
Score 1	Fulfills only 1 of 3 requirements of a level 3 performance
Score 2	Fulfills 2 of 3 requirements of a level 3 performance
Score 3	Calculates the horizontal initial velocity; calculates the vertical initial velocity; calculates the vertical distance traveled by the object

3. A force of 18 N parallel to the ground pulls on a 4.8-kg box, but the box remains at rest.

- What is the frictional force acting on the box? Show your work.
- Draw and label a free-body diagram to explain your answer.

Score 0	No response or the response does not address the prompt
Score 1	Fulfills only 1 of 2 requirements of a level 2 performance
Score 2	Calculates the frictional force acting on the box; draws and labels a free body diagram describing the scenario

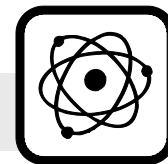

4. After applying a braking force of 290 N, the speed of a 115-kg motorcycle decreased from 45 m/s to 30 m/s.

- How much time did it take for the motorcycle to decrease its speed to 30 m/s? Explain your answer.
- Explain, using Newton's laws of motion, why decreasing the speed of a moving object is not instantaneous.

Score 0 No response or the response does not address the prompt

Score 1 Fulfills only 1 of 2 requirements of a level 2 performance

Score 2 Calculates the amount of time required for the motorcycle to decrease its speed; explains why decreasing speed is not instantaneous using Newton's laws of motion

5. A horizontal force acts on a block, making it slide on a horizontal surface. The force of friction between the block and the surface is 0.5 N.

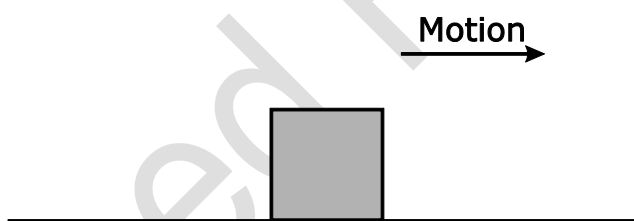

- If the direction of the applied initial force causing the block to slide is reversed, how will this affect the force of friction on the block? Explain your answer.
- How will reversing the initial force affect the net force on the block? Explain your answer.
- How will reversing the initial force affect the acceleration of the block? Explain your answer.

Score 0 No response or the response does not address the prompt

Score 1 Fulfills only 1 of 3 requirements of a level 3 performance

Score 2 Fulfills 2 of 3 requirements of a level 3 performance

Score 3 Explains how reversing the applied force affects the force of friction; explains how reversing the applied force affects the net force; explains how reversing the applied force affects the acceleration of the block

APPENDIX TO CONSTRUCTED RESPONSE KEY PHYSICS

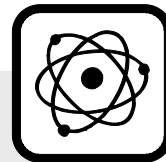

QID	Discrete Answers for Student Responses (* Student answers may vary.)
1	Score Point 1: 38.7Ω or any equivalent/rounded value Score Point 2: 1.6 A or any equivalent/rounded value Score Point 3: *
2	Score Point 1: horizontal $v_i = 6\sqrt{3}$ m/s or 10.4 m/s and vertical $v_i = 6$ m/s Score Point 2: 1.84 m or any equivalent/rounded value
3	Score Point 1: 18 N Score Point 2: *
4	Score Point 1: 5.9 s or any equivalent/rounded value Score Point 2: *
5	Score Point 1: * Score Point 2: * Score Point 3: *

Released Fall 2012